

Operating Systems (Honor Track)

Scheduling 2: Case Studies, Fairness, Real Time, and Forward Progress

Xin Jin

Spring 2026

Recap: First-Come, First-Served (FCFS) Scheduling

- First-Come, First-Served (FCFS)
 - Also “First In, First Out” (FIFO) or “Run until done”
 - » In early systems, FCFS meant one program scheduled until done (including I/O)
 - » Now, means keep CPU until thread blocks



- Example:

<u>Process</u>	<u>Burst Time</u>
P_1	24
P_2	3
P_3	3

- Suppose processes arrive in the order: P_1, P_2, P_3
The Gantt Chart for the schedule is:



- Waiting time for $P_1 = 0$; $P_2 = 24$; $P_3 = 27$
- Average waiting time: $(0 + 24 + 27)/3 = 17$
- Average completion time: $(24 + 27 + 30)/3 = 27$
- **Head-of-line blocking:** short process stuck behind long process

Recap: Round Robin (RR) Scheduling

- FCFS Scheme: Potentially bad for short jobs!
 - Depends on submit order
 - If you are first in line at supermarket with milk, you don't care who is behind you, on the other hand...
- Round Robin Scheme: **Preemption!**
 - Each process gets a small unit of CPU time (*time quantum*), usually 10-100 milliseconds
 - After quantum expires, the process is preempted and added to the end of the ready queue.
 - n processes in ready queue and time quantum is $q \Rightarrow$
 - » Each process gets $1/n$ of the CPU time
 - » In chunks of at most q time units
 - » **No process waits more than $(n-1)q$ time units**

Recap: Handling Differences in Importance: Strict Priority Scheduling

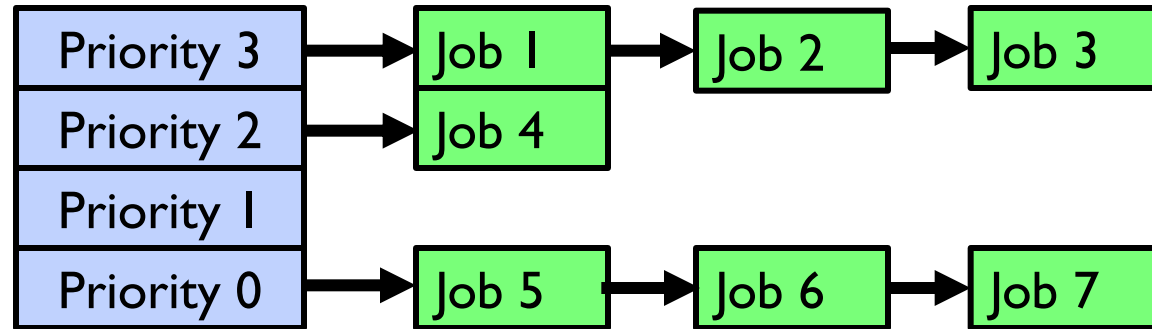

- Execution Plan
 - Always execute highest-priority runnable jobs to completion
 - Each queue can be processed in RR with some time-quantum
- Problems:
 - Starvation:
 - » Lower priority jobs don't get to run because higher priority jobs
 - Deadlock: Priority Inversion
 - » Happens when low priority task has lock needed by high-priority task
 - » Usually involves third, intermediate priority task preventing high-priority task from running
- How to fix problems?
 - Dynamic priorities: adjust base-level priority up or down based on heuristics about interactivity, locking, burst behavior, etc...

Recap: What if we Knew the Future?

- Could we always mirror best FCFS?
- Shortest Job First (SJF):
 - Run whatever job has least amount of computation to do
 - Sometimes called “Shortest Time to Completion First” (STCF)
- Shortest Remaining Time First (SRTF):
 - Preemptive version of SJF: if job arrives and has a shorter time to completion than the remaining time on the current job, immediately preempt CPU
 - Sometimes called “Shortest Remaining Time to Completion First” (SRTCF)
- These can be applied to whole program or current CPU burst
 - Idea is to get short jobs out of the system
 - Big effect on short jobs, only small effect on long ones
 - Result is better average completion time



Predicting the Length of the Next CPU Burst

- **Adaptive:** Changing policy based on past behavior
 - CPU scheduling, in virtual memory, in file systems, etc
 - Works because programs have predictable behavior
 - » If program was I/O bound in past, likely in future
 - » If computer behavior were random, wouldn't help
- Example: SRTF with estimated burst length
 - Use an estimator function on previous bursts:
Let $t_{n-1}, t_{n-2}, t_{n-3}$, etc. be previous CPU burst lengths.
Estimate next burst $\tau_n = f(t_{n-1}, t_{n-2}, t_{n-3}, \dots)$
 - Function f could be one of many different time series estimation schemes (Kalman filters, etc)
 - For instance,

exponential averaging

$$\tau_n = \alpha t_{n-1} + (1-\alpha)\tau_{n-1}$$

with $(0 < \alpha \leq 1)$

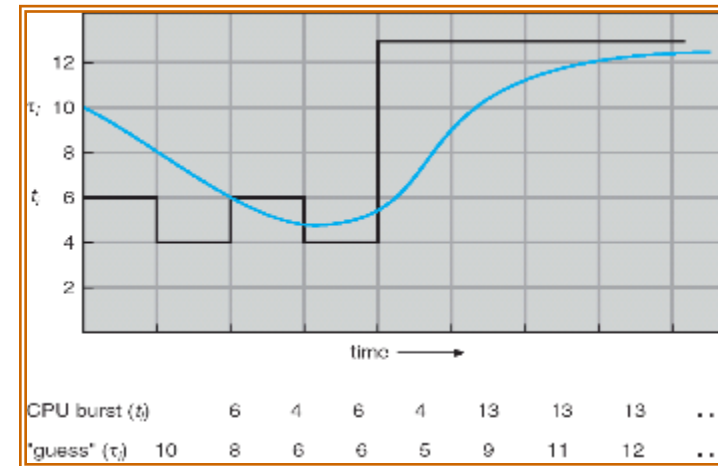

Lottery Scheduling

- Yet another alternative: Lottery Scheduling
 - Give each job some number of lottery tickets
 - On each time slice, randomly pick a winning ticket
 - On average, CPU time is proportional to number of tickets given to each job
- How to assign tickets?
 - To approximate SRTF, short running jobs get more, long running jobs get fewer
 - To avoid starvation, every job gets at least one ticket (everyone makes progress)
- Advantage over strict priority scheduling: behaves gracefully as load changes
 - Adding or deleting a job affects all jobs proportionally, independent of how many tickets each job possesses



Lottery Scheduling Example (Cont.)

- Lottery Scheduling Example

- Assume short jobs get 10 tickets, long jobs get 1 ticket

# short jobs/ # long jobs	% of CPU each short jobs gets	% of CPU each long jobs gets
1/1	91%	9%
0/2	N/A	50%
2/0	50%	N/A
10/1	9.9%	0.99%
1/10	50%	5%

- What if too many short jobs to give reasonable completion time?
 - » If load average is 100, hard to make progress
 - » One approach: log some user out

Multi-Level Feedback Scheduling

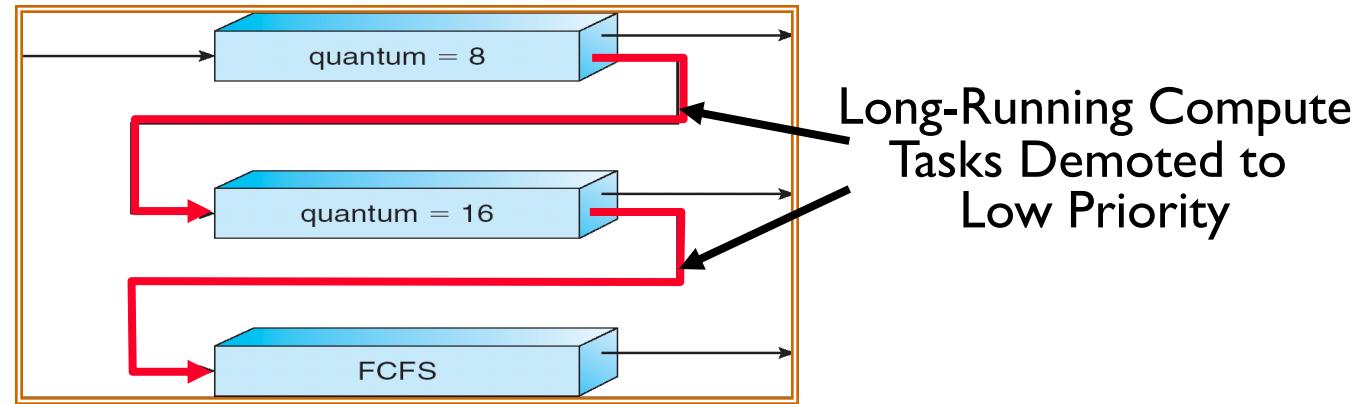

- Another method for exploiting past behavior (first use in CTSS)
 - Multiple queues, each with different priority
 - » Higher priority queues often considered “foreground” tasks
 - Each queue has its own scheduling algorithm
 - » e.g. foreground – RR, background – FCFS
 - » Sometimes multiple RR priorities with quantum increasing exponentially (highest:1ms, next: 2ms, next: 4ms, etc)
- Adjust each job’s priority as follows (details vary)
 - Job starts in highest priority queue
 - If timeout expires, drop one level
 - If timeout doesn’t expire, push up one level (or to top)

Scheduling Details

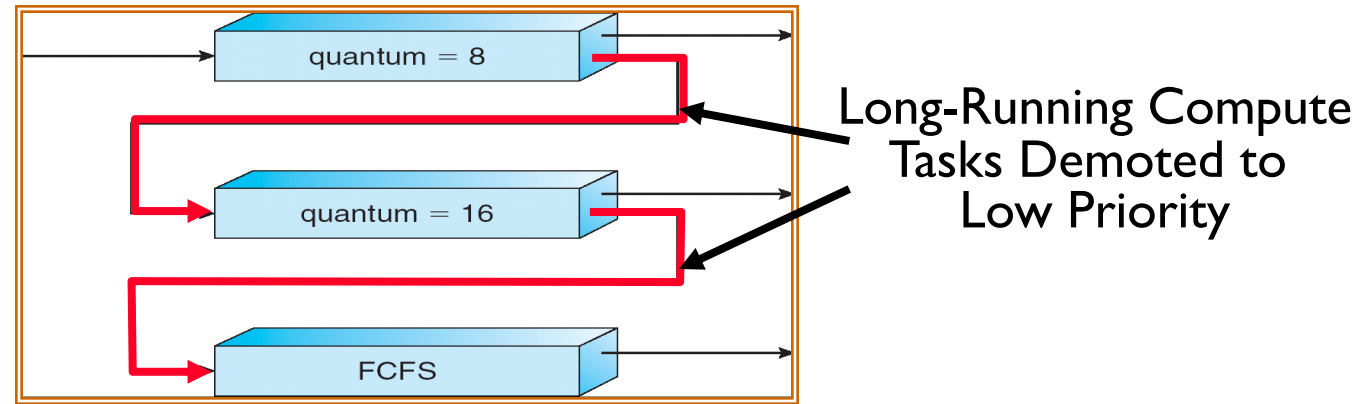

- Result approximates SRTF:
 - CPU bound jobs drop like a rock
 - Short-running I/O bound jobs stay near top
- Scheduling must be done between the queues
 - **Fixed priority scheduling:**
 - » serve all from highest priority, then next priority, etc.
 - **Time slice:**
 - » each queue gets a certain amount of CPU time
 - » e.g., 70% to highest, 20% next, 10% lowest

Scheduling Details

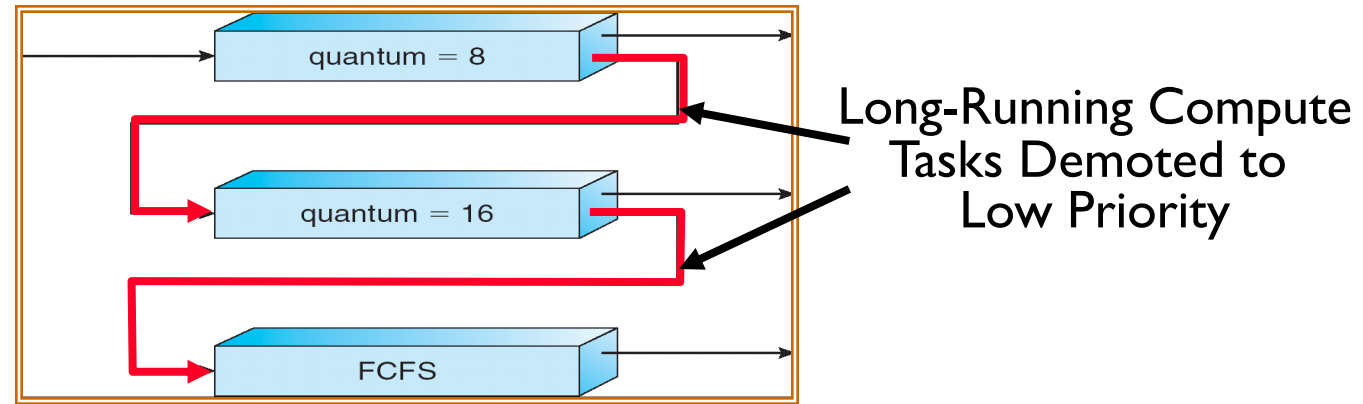

- **Countermeasure:** user action that can foil intent of the OS designers
 - For multilevel feedback, put in a bunch of meaningless I/O to keep job's priority high
 - Of course, if everyone did this, wouldn't work!
- Example of Othello program:
 - Playing against competitor, so key was to do computing at higher priority than the competitors.
 - » Put in printf's, run much faster!

How to Handle Simultaneous Mix of Diff Types of Apps?

- Consider mix of interactive and high throughput apps:
 - How to best schedule them?
 - How to recognize one from the other?
 - » Do you trust app to say that it is “interactive”?
 - Should you schedule the set of apps identically on servers, workstations, pads, and cellphones?
- For instance, is Burst Time (observed) useful to decide which application gets CPU time?
 - Short Bursts \Rightarrow Interactivity \Rightarrow High Priority?
- Assumptions encoded into many schedulers:
 - Apps that sleep a lot and have short bursts must be interactive apps – they should get high priority
 - Apps that compute a lot should get low(er?) priority, since they won't notice intermittent bursts from interactive apps
- Hard to characterize apps:
 - What about apps that sleep for a long time, but then compute for a long time?
 - Or, what about apps that must run under all circumstances (say periodically)

Multi-Core Scheduling

- Algorithmically, not a huge difference from single-core scheduling
- Implementation-wise, helpful to have *per-core* scheduling data structures
 - Cache coherence
- *Affinity scheduling*: once a thread is scheduled on a CPU, OS tries to reschedule it on the same CPU
 - Cache reuse

Spinlocks for multiprocessing

- Spinlock implementation:

```
int value = 0; // Free
Acquire() {
    while (test&set(&value)) {}; // spin while busy
}
Release() {
    value = 0; // atomic store
}
```

- Spinlock doesn't put the calling thread to sleep—it just busy waits
 - When might this be preferable?
 - » Waiting for limited number of threads at a barrier in a multiprocessing (multicore) program
 - » Wait time at barrier would be greatly increased if threads must be woken inside kernel
- Every `test&set()` is a write, which makes value ping-pong around between core-local caches
 - So – really want to use `test&test&set()` !
- The extra read eliminates the ping-ponging issues:

```
// Implementation of test&test&set():
Acquire() {
    do {
        while(value); // wait until might be free
    } while (test&set(&value)); // exit if acquire lock
}
```

Gang Scheduling and Parallel Applications

- When multiple threads work together on a multi-core system, try to schedule them together
 - Makes spin-waiting more efficient (inefficient to spin-wait for a thread that's suspended)
- Alternative: OS informs a parallel program how many processors its threads are scheduled on (*Scheduler Activations*)
 - Application adapts to number of cores that it has scheduled
 - “Space sharing” with other parallel programs can be more efficient, because parallel speedup is often sublinear with the number of cores

So, Does the OS Schedule Processes or Threads?

- Many textbooks use the “old model”—one thread per process
- Usually it's really: **threads** (e.g., in Linux)
- One point to notice: switching threads vs. switching processes incurs different costs:
 - Switch threads: Save/restore registers
 - Switch processes: Change active address space too!
 - » Expensive
 - » Disrupts caching

Real-Time Scheduling

- Goal: **Predictability** of Performance!
 - We need to predict with confidence worst case response times for systems!
 - In RTS, performance guarantees are:
 - » Task- and/or class centric and often ensured a priori
 - In conventional systems, performance is:
 - » System/throughput oriented with post-processing (... wait and see ...)
 - Real-time is about enforcing *predictability*; does not equal fast computing!!!
- Hard real-time: for time-critical safety-oriented systems
 - Meet all deadlines (if at all possible)
 - Ideally: determine in advance if this is possible (admission control)
 - **Earliest Deadline First (EDF)**, Rate-Monotonic Scheduling (RMS), Deadline Monotonic Scheduling (DM)
- Soft real-time: for multimedia
 - Attempt to meet deadlines with high probability
 - Constant Bandwidth Server (CBS)

Example: Workload Characteristics

- Tasks are preemptable, independent with arbitrary arrival (=release) times
- Tasks have deadlines (D) and known computation times (C)
- Example Setup:

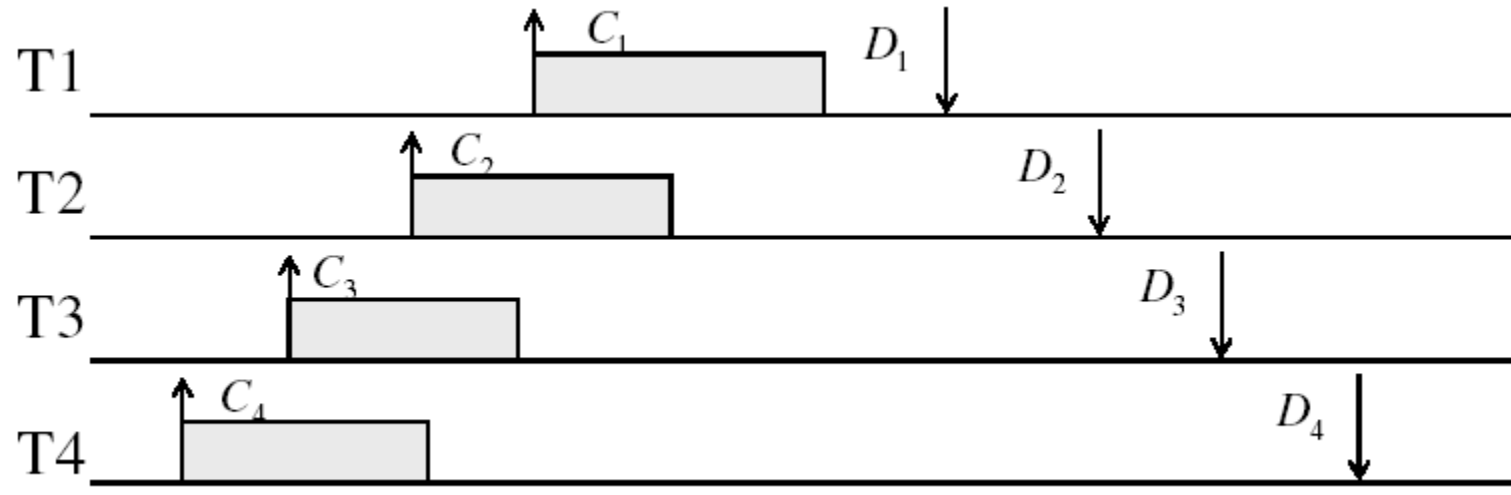

Example: Round-Robin Scheduling Doesn't Work

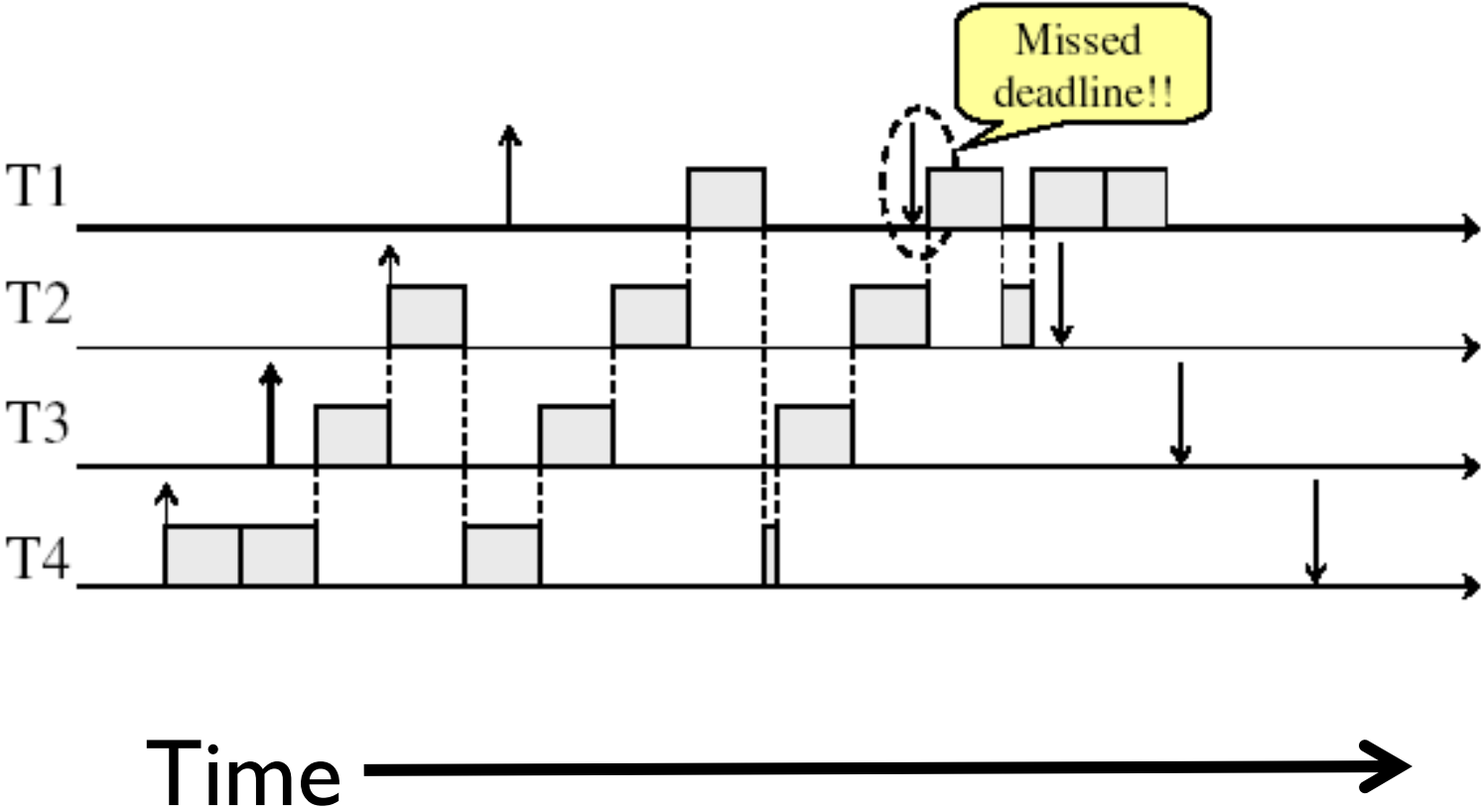

Earliest Deadline First (EDF)

- Tasks i is **periodic** with period P_i and computation C_i in each period: (P_i, C_i) for each task i
- Preemptive priority-based dynamic scheduling:
 - Each task is assigned a (current) priority based on how close the absolute deadline is (i.e. $D_i^{t+1} = D_i^t + P_i$ for each task!)
 - **The scheduler always schedules the active task with the closest absolute deadline**

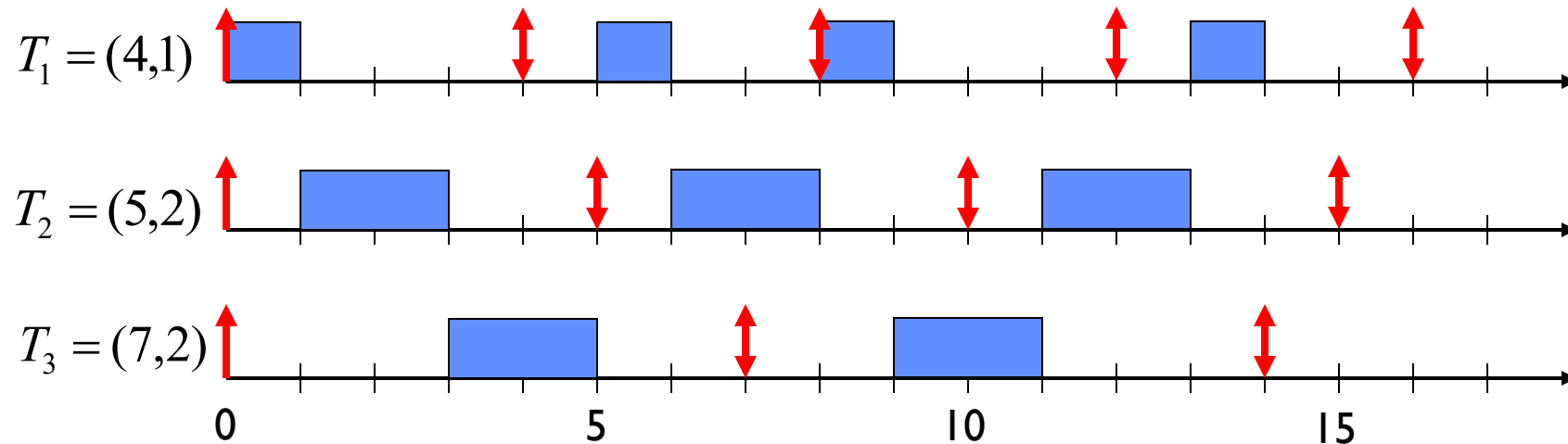

EDF Feasibility Testing

- Even EDF won't work if you have too many tasks
- For n tasks with computation time C_i and deadline D_i , a feasible schedule exists if:

$$\sum_{i=1}^n \left(\frac{C_i}{D_i} \right) \leq 1$$

$$\frac{1}{4} + \frac{2}{5} + \frac{2}{7} = 0.936 \leq 1$$

Ensuring Progress

- Starvation: thread fails to make progress for an indefinite period of time
- Starvation \neq Deadlock
 - Deadlock: cyclic requests for resources
- Let's explore what sorts of problems we might encounter and how to avoid them...

Strawman: Non-Work-Conserving Scheduler

- A *work-conserving* scheduler is one that does not leave the CPU idle when there is work to do
- A non-work-conserving scheduler could trivially lead to starvation
- In this class, we'll assume that the scheduler is work-conserving (unless stated otherwise)

Strawman: Last-Come, First-Served (LCFS)

- Stack (LIFO) as a scheduling data structure
 - Late arrivals get fast service
 - Early ones wait – extremely unfair
 - In the worst case – *starvation*
- When would this occur?
 - When arrival rate (offered load) exceeds service rate (delivered load)
 - Queue builds up faster than it drains
- Queue can build in FIFO too, but “serviced in the order received” ...

Is FCFS Prone to Starvation?

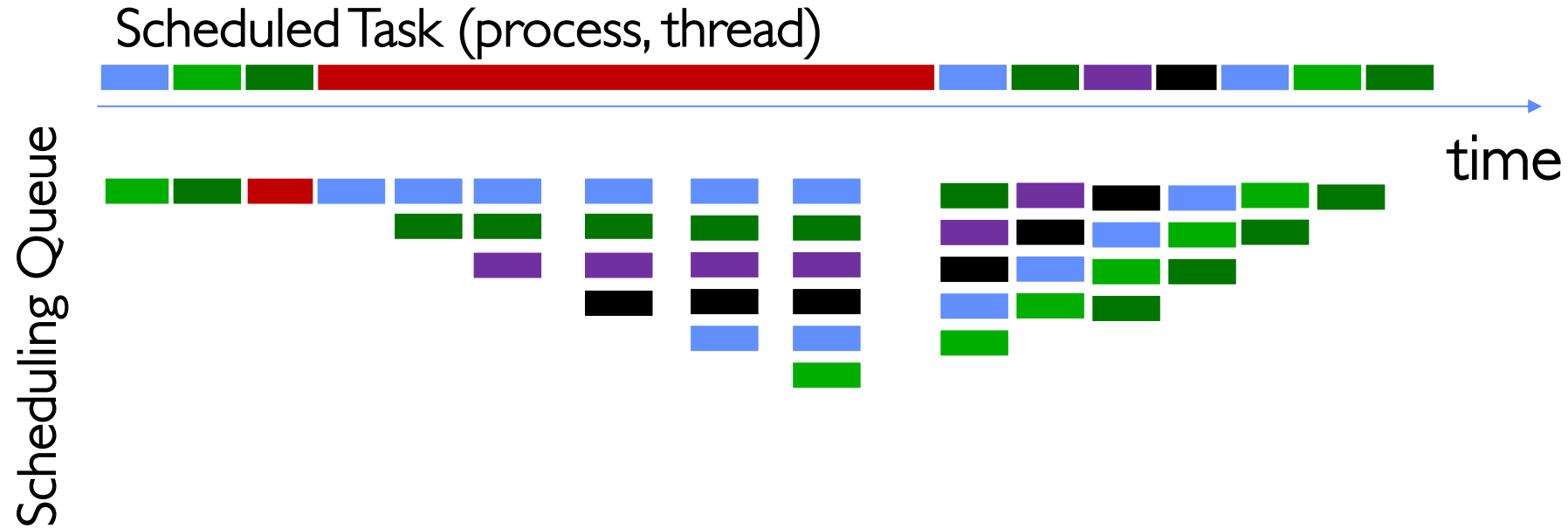

- If a task never yields (e.g., goes into an infinite loop), then other tasks don't get to run
- Problem with all non-preemptive schedulers...
 - And early personal OSes such as original MacOS, Windows 3.1, etc.

Is Round Robin (RR) Prone to Starvation?

- Each of N processes gets $\sim 1/N$ of CPU (in window)
 - With quantum length Q ms, process waits at most $(N-1)*Q$ ms to run again
 - So a process can't be kept waiting indefinitely
- So RR is fair in terms of *waiting time*
 - Not necessarily in terms of throughput...

Is Priority Scheduling Prone to Starvation?

- Recall: Priority Scheduler always runs the thread with highest priority
 - Low priority thread might never run!
 - Starvation...

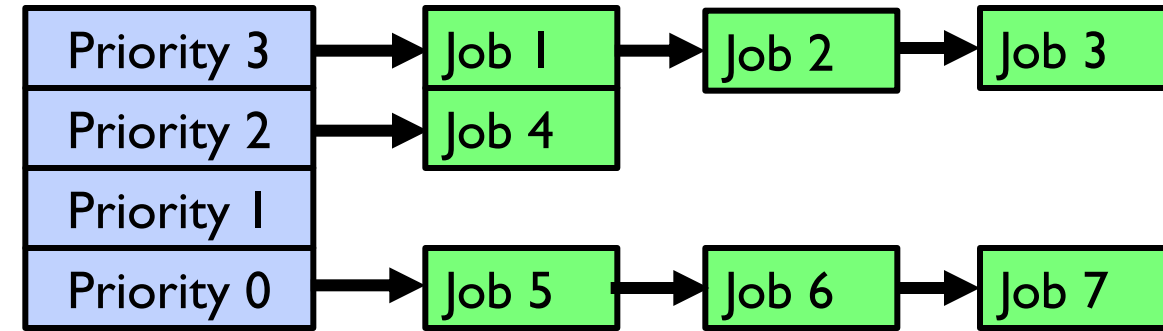

- But there are more serious problems as well...
 - Priority inversion: even high priority threads might become starved

Priority Inversion

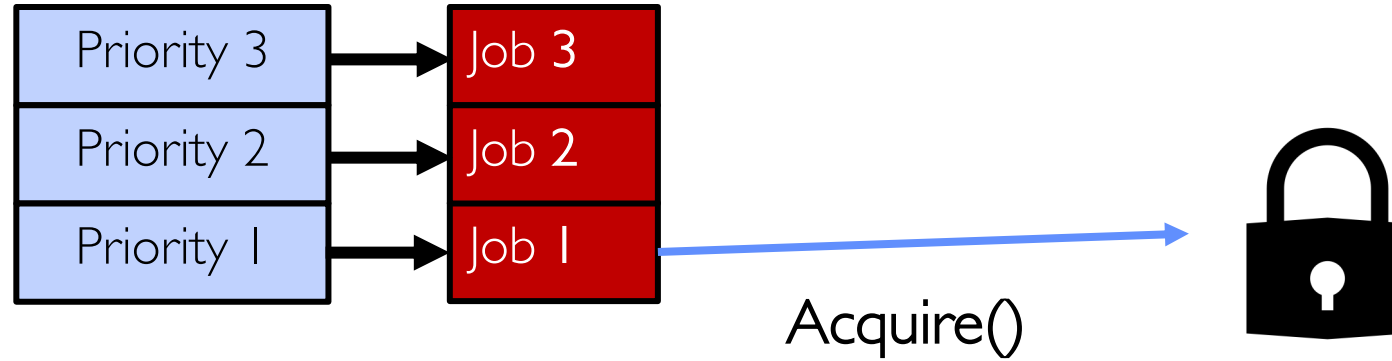

- At this point, which job does the scheduler choose?
- Job 3 (Highest priority)

Priority Inversion

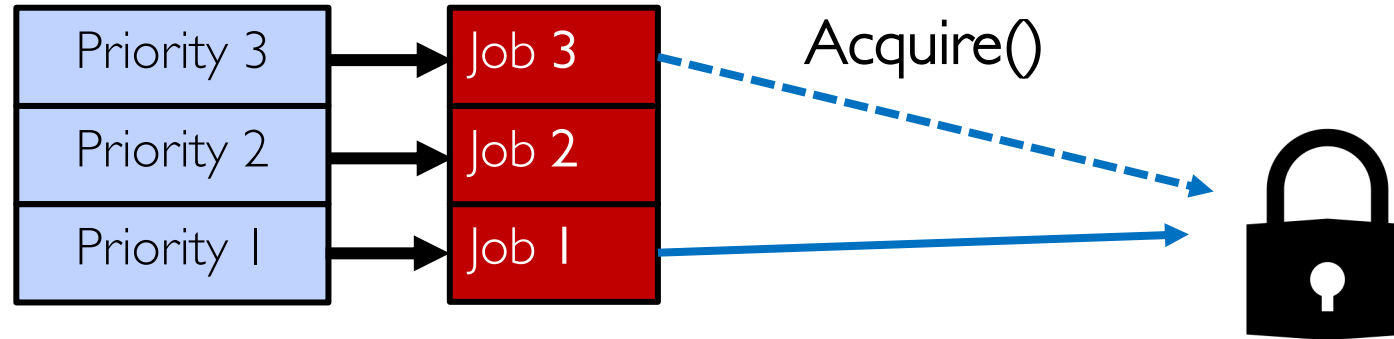

- Job 3 attempts to acquire lock held by Job 1

Priority Inversion

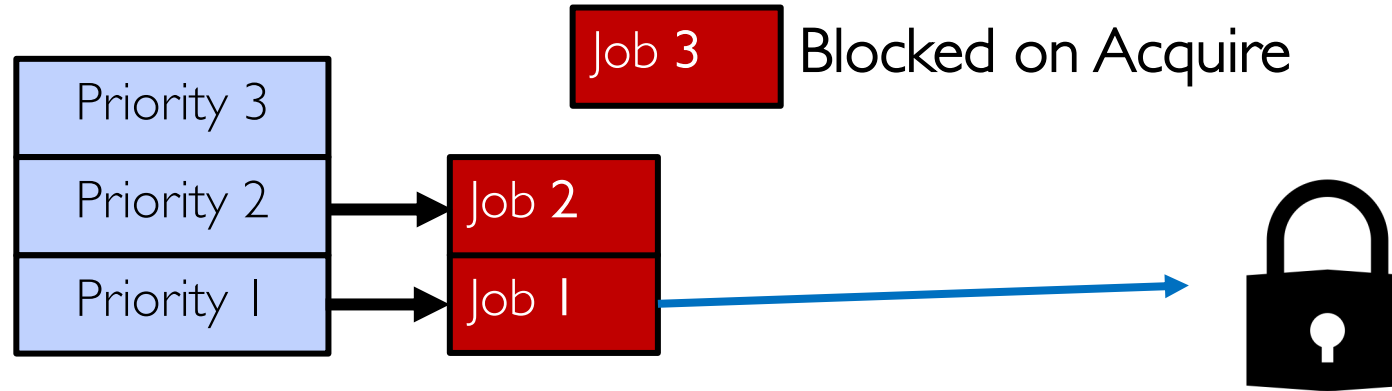

- At this point, which job does the scheduler choose?
- Job 2 (Medium Priority)
- Priority Inversion

Priority Inversion

- Where high priority task is blocked waiting on low priority task
- Low priority one *must* run for high priority to make progress
- Medium priority task can starve a high priority one
- When else might priority lead to starvation or “live lock”?



One Solution: Priority Donation/Inheritance

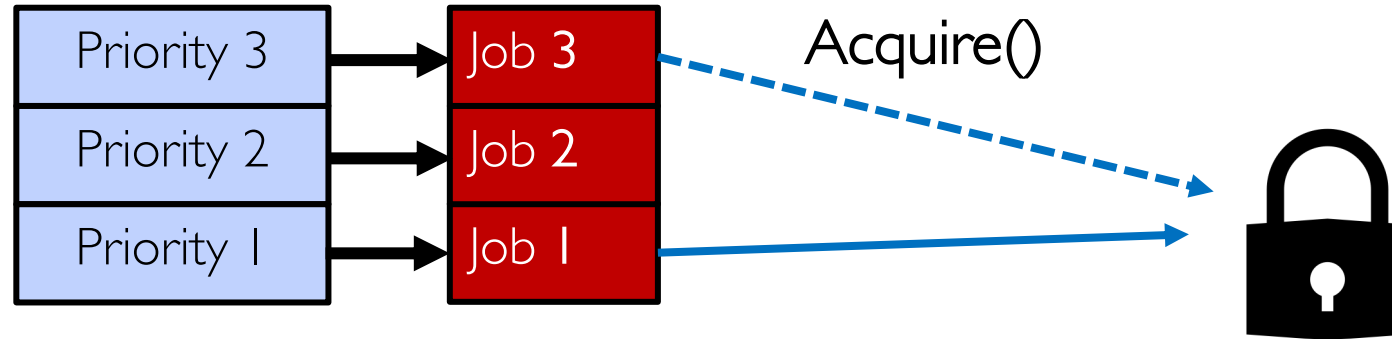

- Job 3 temporarily grants Job 1 its “high priority” to run on its behalf

One Solution: Priority Donation/Inheritance

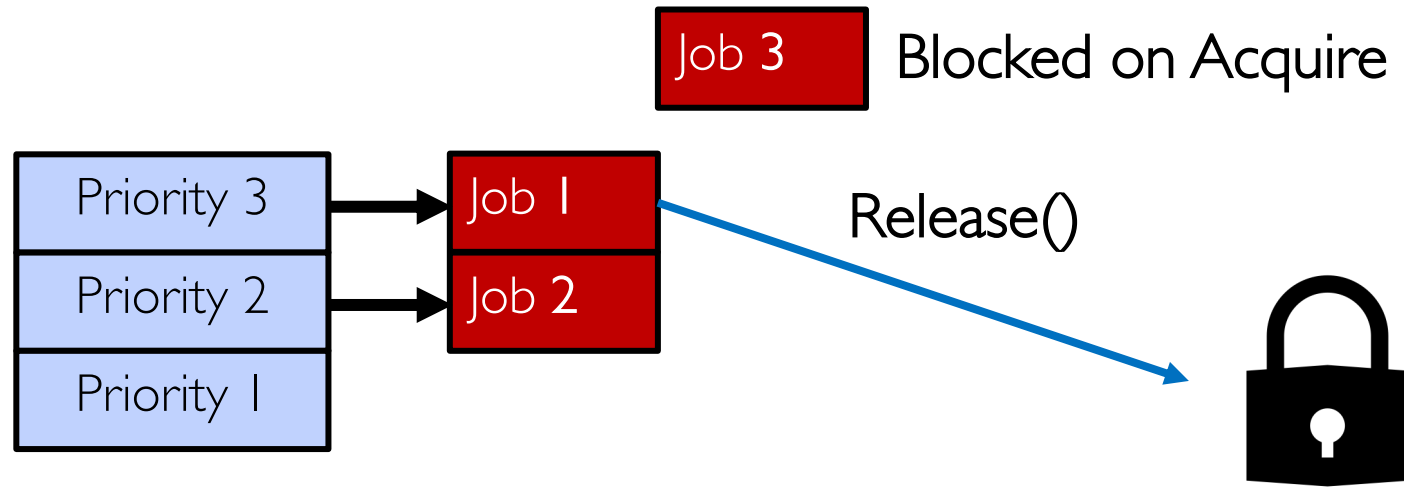

- Job 3 temporarily grants Job 1 its “high priority” to run on its behalf

One Solution: Priority Donation/Inheritance

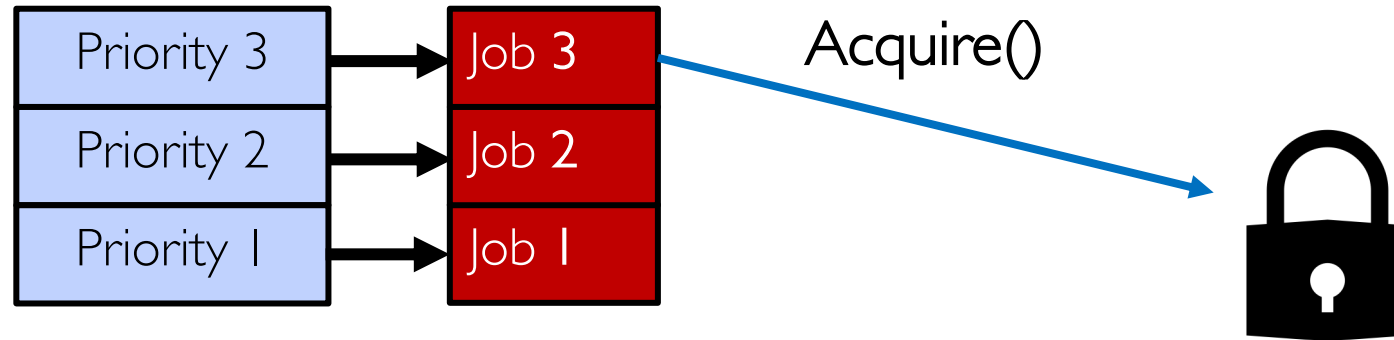

- Job 1 completes critical section and releases lock
- Job 3 acquires lock, runs again

Case Study: Martian Pathfinder Rover

- July 4, 1997 – Pathfinder lands on Mars
 - First US Mars landing since Vikings in 1976; first rover
 - Novel delivery mechanism: inside air-filled balloons bounced to stop on the surface from orbit!



- And then...a few days into mission...:
 - Multiple system resets occur to realtime OS (VxWorks)
 - System would reboot randomly, losing valuable time and progress

- Problem? Priority Inversion!

- Low priority task grabs mutex trying to communicate with high priority task

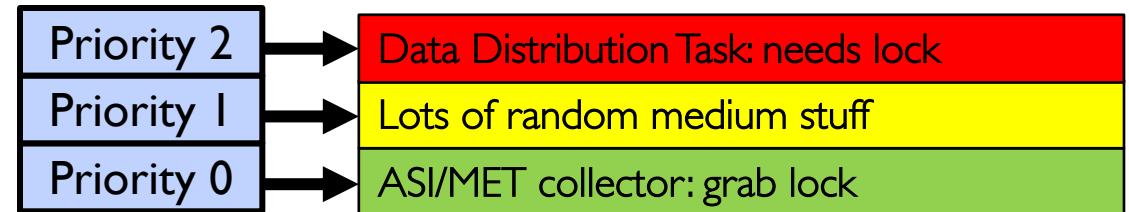

- Realtime watchdog detected lack of forward progress and invoked reset to safe state
 - » High-priority data distribution task was supposed to complete with regular deadline

- Solution: Turn priority donation back on and upload fixes!
- Original developers turned off priority donation (also called priority inheritance)
 - Worried about performance costs of donating priority!

Are SRTF and MLFQ Prone to Starvation?

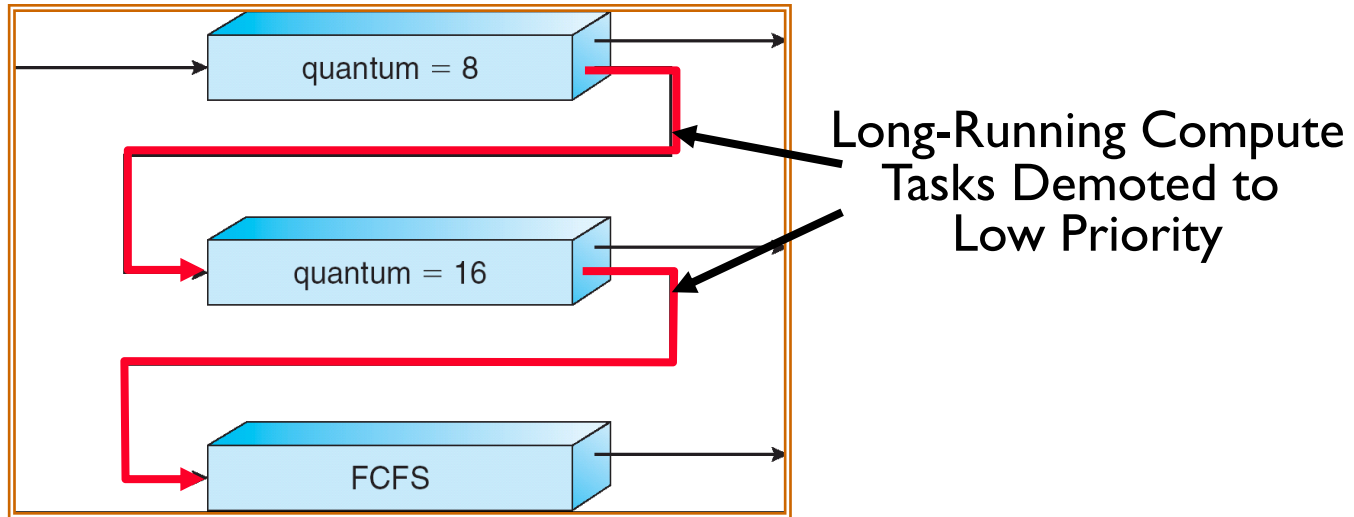

- In SRTF, long jobs are starved in favor of short ones
 - Same fundamental problem as priority scheduling
- MLFQ is an approximation of SRTF, so it suffers from the same problem

Cause for Starvation: Priorities?

- Most of policies we've studied so far:
 - **Always prefer to give the CPU to a prioritized job**
 - Non-prioritized jobs may never get to run
- But priorities were a means, not an end
- Our end goal was to serve a mix of CPU-bound, I/O bound, and Interactive jobs effectively on common hardware
 - Give the I/O bound ones enough CPU to issue their next file operation and wait (on those slow discs)
 - Give the interactive ones enough CPU to respond to an input and wait (on those slow humans)
 - Let the CPU bound ones grind away without too much disturbance

Recall: Changing Landscape...

Bell's Law: New computer class every 10 years

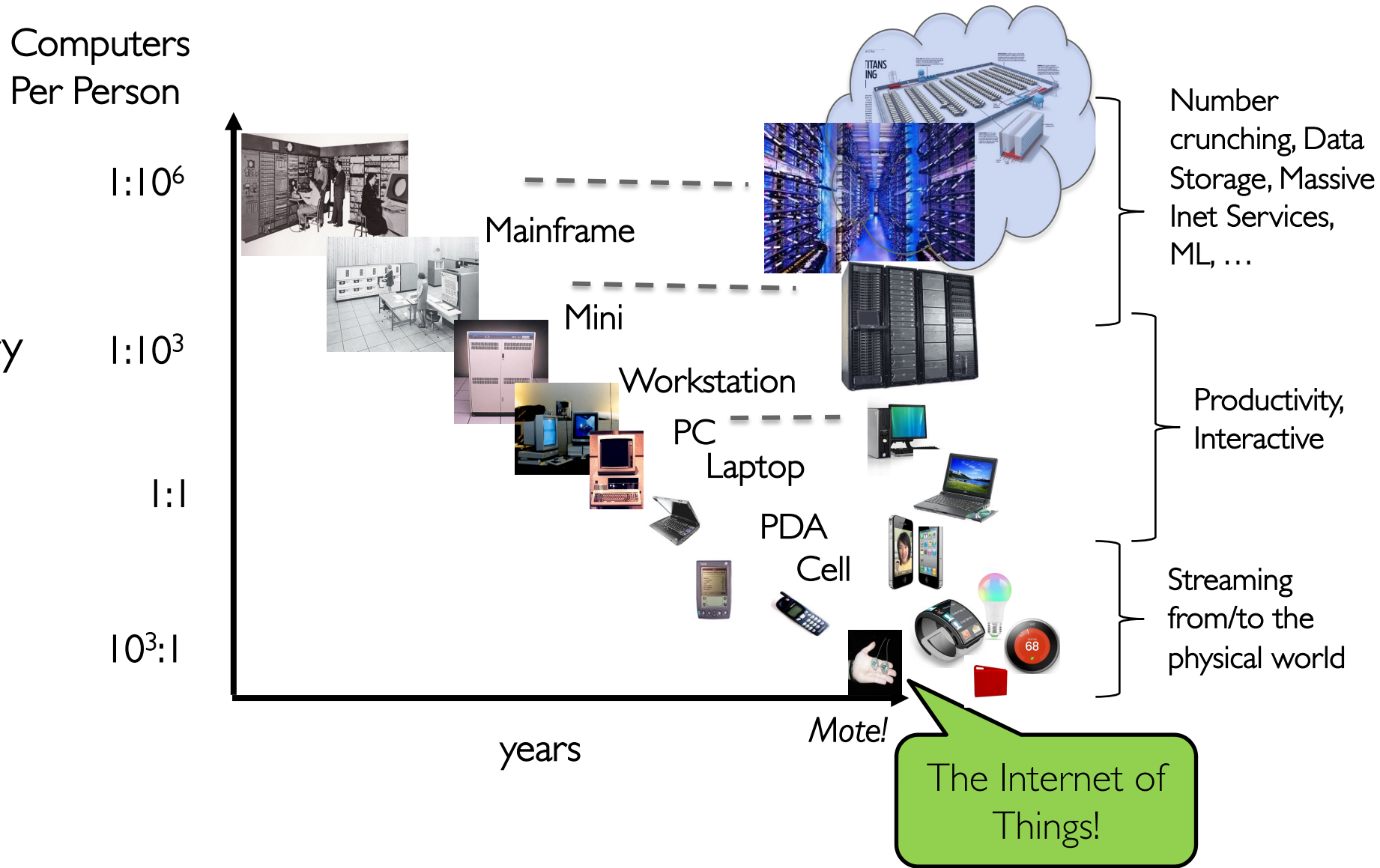

Changing Landscape of Scheduling

- Priority-based scheduling rooted in “time-sharing”
 - Allocating precious, limited resources across a diverse workload
 - » CPU bound vs. interactive vs. I/O bound
- 80’s brought about personal computers, workstations, and servers on networks
 - Different machines of different types for different purposes
 - Shift to fairness and avoiding extremes (starvation)
- 90’s emergence of the web, rise of internet-based services, the data-center-is-the-computer
 - Server consolidation, massive clustered services, huge flashcrowds
 - It’s about predictability, 95th percentile performance guarantees

Priority in Unix – Being Nice

- The industrial operating systems of the 60s and 70s provided priority to enforce desired usage policies.
 - When it was being developed at Berkeley, instead it provided ways to “be nice”.
- `nice` values range from -20 to 19
 - Negative values are “not nice”
 - If you wanted to let your friends get more time, you would nice up your job
- Scheduler puts higher nice-value tasks (lower priority) to sleep more ...
 - In $O(1)$ scheduler, this translated fairly directly to priority (and time slice)

Case Study: Linux O(1) Scheduler



- Priority-based scheduler: 140 priorities
 - 40 for “user tasks” (set by “nice”), 100 for “Realtime/Kernel”
 - Lower nice value \Rightarrow higher priority
 - Higher nice value \Rightarrow lower priority
 - All algorithms $O(1)$
 - » Timeslices/priorities/interactivity credits all compute when job finishes time slice
 - » 140-bit bit mask indicates presence or absence of job at given priority level
- Two separate priority queues: “active” and “expired”
 - All tasks in the active queue use up their timeslices and get placed on the expired queue, after which queues swapped
- Timeslice depends on priority – linearly mapped onto timeslice range
 - Like a multi-level queue (one queue per priority) with different timeslice at each level
 - Execution split into “Timeslice Granularity” chunks – round robin through priority

Linux O(1) Scheduler

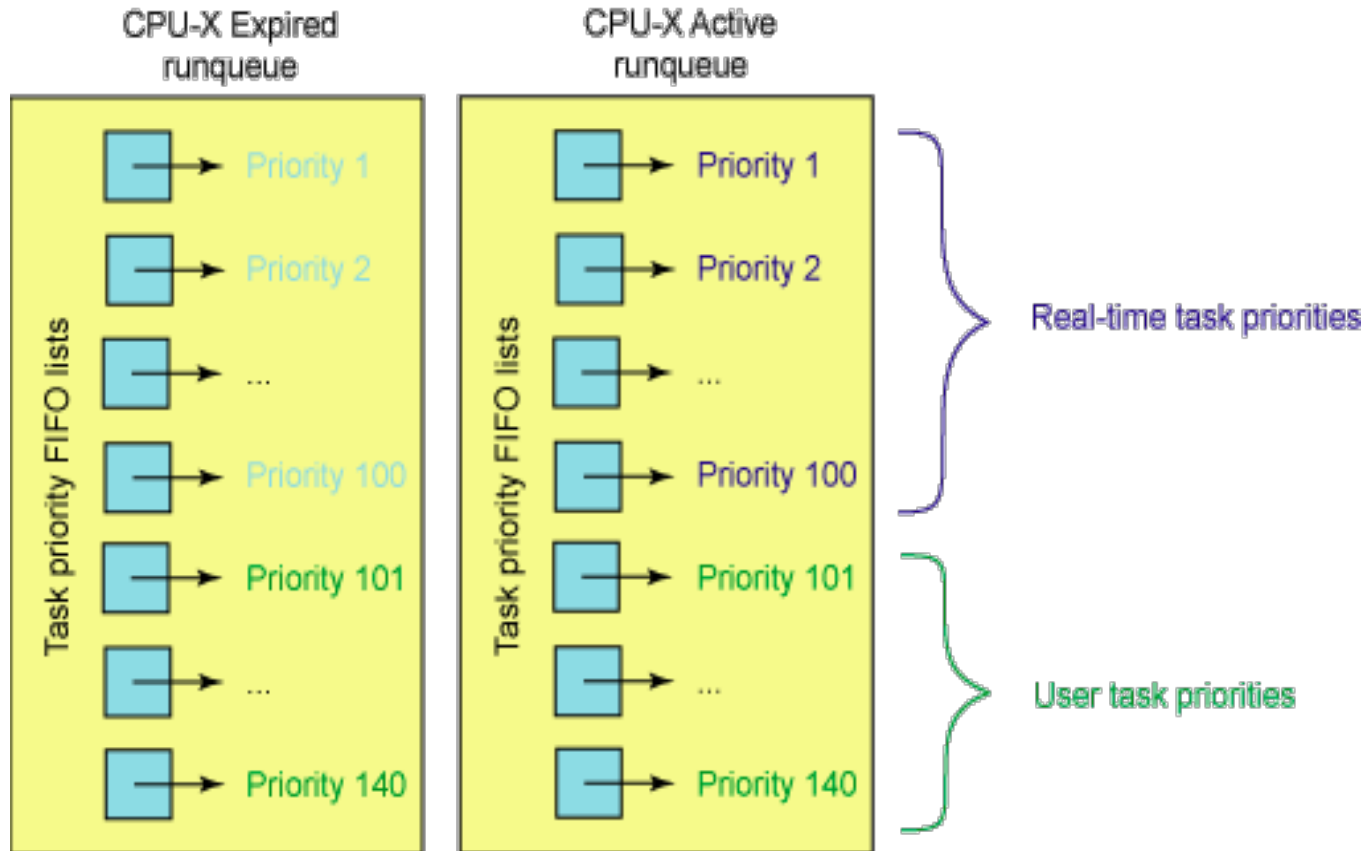

- Lots of ad-hoc heuristics
 - Try to boost priority of I/O-bound tasks
 - Try to boost priority of starved tasks

O(1) Scheduler Continued

- Heuristics
 - User-task priority adjusted ± 5 based on heuristics
 - » $P \rightarrow \text{sleep_avg} = (\text{sleep_time} - \text{run_time}) \times \text{coefficient}$
 - » Higher sleep_avg \Rightarrow more I/O bound the task, more reward (and vice versa)
 - Interactive Credit
 - » Earned when a task sleeps for a “long” time
 - » Spend when a task runs for a “long” time
 - » IC is used to provide hysteresis to avoid changing interactivity for temporary changes in behavior
 - However, “interactive tasks” get special dispensation
 - » To try to maintain interactivity
 - » Placed back into active queue, unless some other task has been starved for too long...
- Real-Time Tasks
 - Always preempt non-RT tasks
 - No dynamic adjustment of priorities
 - Scheduling schemes:
 - » SCHED_FIFO: preempts other tasks, no timeslice limit
 - » SCHED_RR: preempts normal tasks, RR scheduling amongst tasks of same priority

Proportional-Share Scheduling

- Instead using priorities, share the CPU *proportionally*
 - Give each job a share of the CPU according to its priority
 - Low-priority jobs get to run less often
 - But all jobs can at least make progress (no starvation)

Recall: Lottery Scheduling

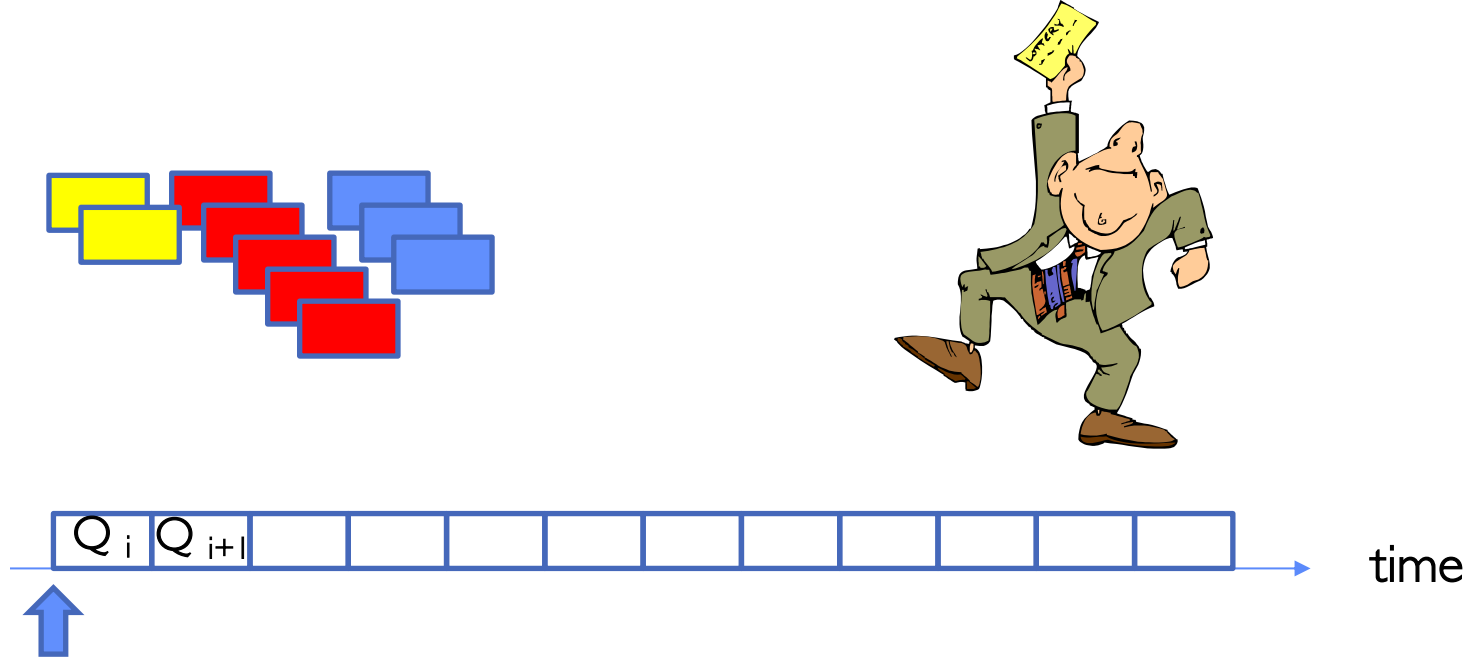

- Given a set of jobs (the mix), provide each with a share of a resource
 - e.g., 50% of the CPU for **Job A**, 30% for **Job B**, and 20% for **Job C**
- Idea: Give out tickets according to the proportion each should receive,
- Every quantum (tick): draw one at random, schedule that job (thread) to run

Lottery Scheduling: Simple Mechanism

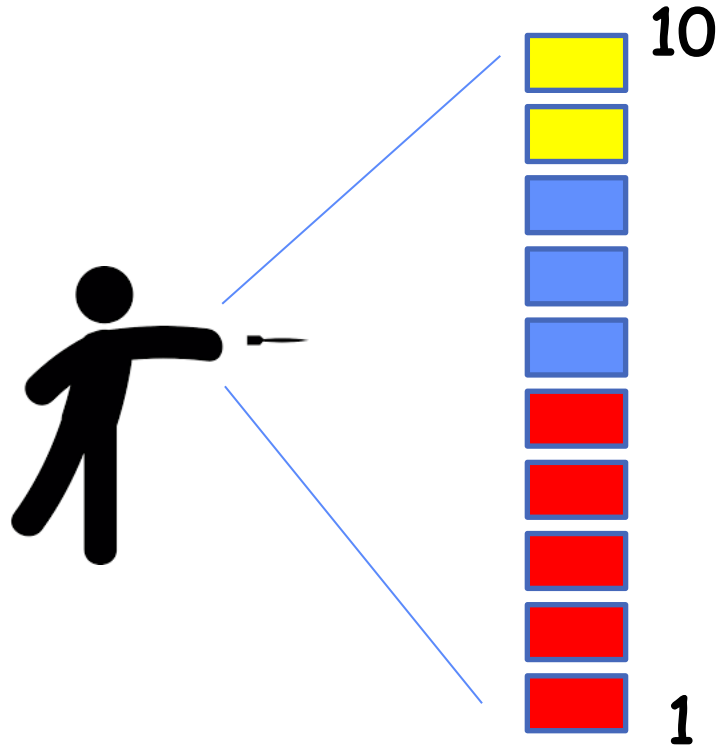

- $N_{ticket} = \sum N_i$
- Pick a number d in $1 \dots N_{ticket}$ as the random “dart”
- Jobs record their N_i of allocated tickets
- Order them by N_i
- Select the first j such that $\sum N_i$ up to j exceeds d .

Linux Completely Fair Scheduler (CFS)

- Basic Idea: track CPU time per thread and schedule threads to match up average rate of execution
- Scheduling Decision:
 - “Repair” illusion of complete fairness
 - Choose thread with minimum CPU time
 - Closely related to Fair Queueing
- Use a heap-like scheduling queue for this...
 - $O(\log N)$ to add/remove threads, where N is number of threads
- Sleeping threads don't advance their CPU time, so they get a boost when they wake up again...
 - Get interactivity automatically!

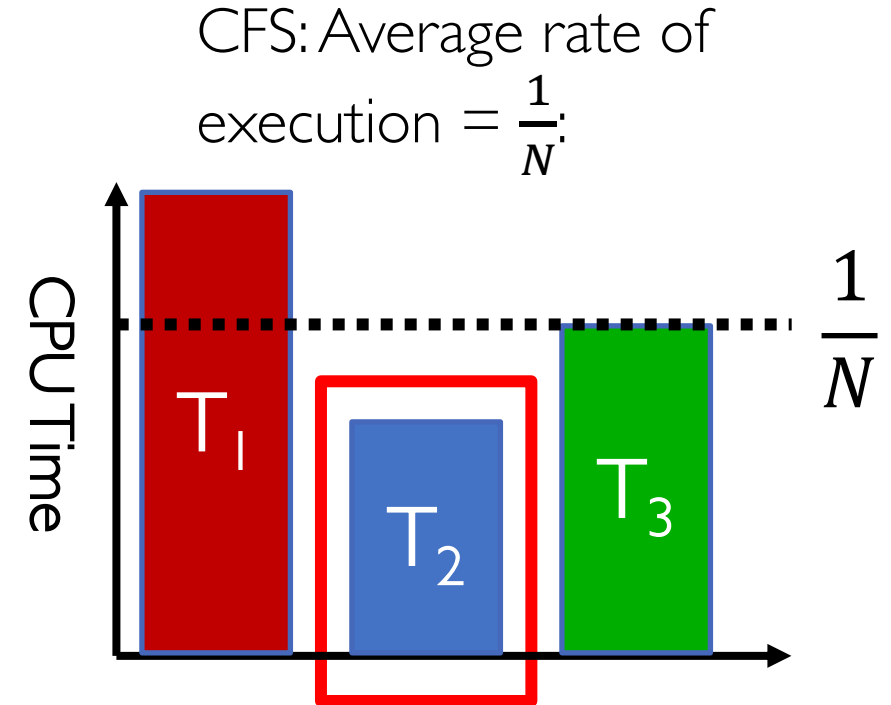

Linux CFS: Responsiveness/Starvation Freedom

- In addition to fairness, we want **low waiting time** and starvation freedom
 - Make sure that everyone gets to run at least a bit!
- Constraint 1: *Target Latency*
 - Period of time over which every process gets service
 - Quanta = Target_Latency / n (n: number of processes)
- Target Latency: 20 ms, 4 Processes
 - Each process gets 5ms time slice
- Target Latency: 20 ms, 200 Processes
 - Each process gets **0.1ms** time slice (!!!)
 - Recall Round-Robin: large context switching overhead if slice gets to small

Linux CFS: Throughput

- Goal: Throughput
 - Avoid excessive overhead
- Constraint 2: Minimum Granularity
 - Minimum length of any time slice
- Target Latency 20 ms, Minimum Granularity 1 ms, 100 processes
 - Each process gets 1 ms time slice

Linux CFS: Proportional Shares

- What if we want to give more CPU to some and less to others in CFS (proportional share) ?
 - Allow different threads to have different *rates* of execution (cycles/time)
- Use weights: assign a weight w_i to each process i to compute the switching quanta Q_i
 - Basic equal share: $Q_i = \text{Target Latency} \cdot \frac{1}{N}$
 - Weighted Share: $Q_i = \left(\frac{w_i}{\sum_p w_p} \right) \cdot \text{Target Latency}$
- Reuse nice value to reflect share, rather than priority
 - Remember that lower nice value \Rightarrow higher priority
 - CFS uses nice values to scale weights exponentially: $\text{Weight} = 1024 / (1.25)^{\text{nice}}$
 - » Two CPU tasks separated by nice value of 5 \Rightarrow
Task with lower nice value has 3 times the weight, since $(1.25)^5 \approx 3$

Choosing the Right Scheduler

I Care About:	Then Choose:
CPU Throughput	
Avg. Completion Time	
I/O Throughput	
Fairness (CPU Time)	
Fairness (Wait Time to Get CPU)	
Meeting Deadlines	
Favoring Important Tasks	

Choosing the Right Scheduler

I Care About:	Then Choose:
CPU Throughput	FCFS
Avg. Completion Time	SRTF Approximation
I/O Throughput	SRTF Approximation
Fairness (CPU Time)	Linux CFS
Fairness (Wait Time to Get CPU)	Round Robin
Meeting Deadlines	EDF
Favoring Important Tasks	Priority

How to Evaluate a Scheduling algorithm?

- Deterministic modeling
 - takes a predetermined workload and compute the performance of each algorithm for that workload
- Queueing models
 - Mathematical approach for handling stochastic workloads
- Implementation/Simulation:
 - Build system which allows actual algorithms to be run against actual data
 - Most flexible/general

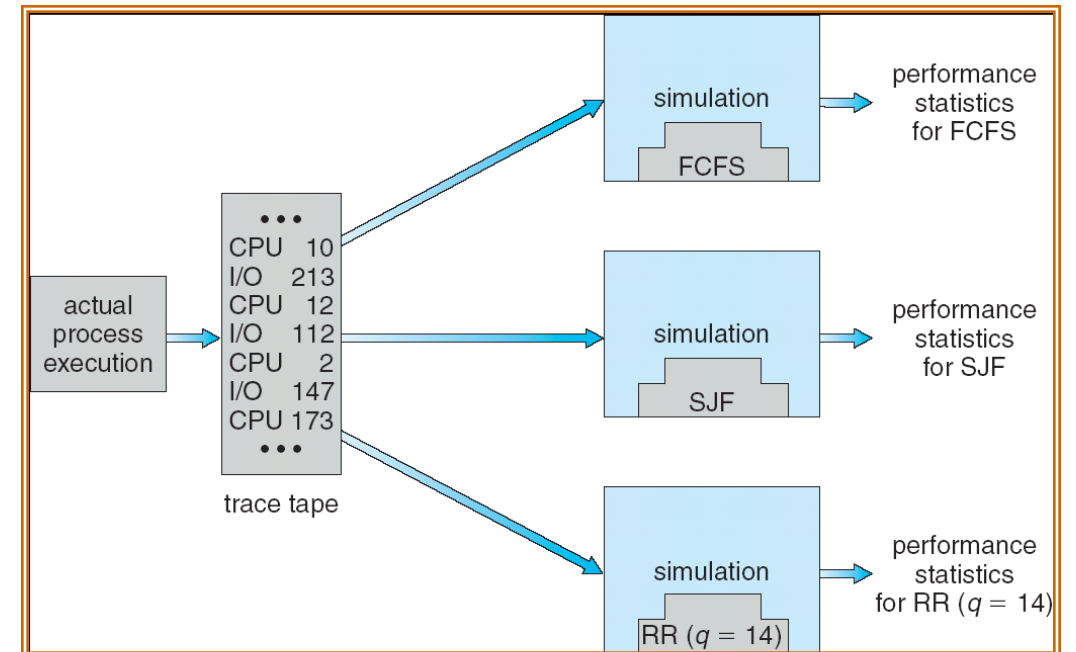

A Final Word On Scheduling

- When do the details of the scheduling policy and fairness really matter?
 - When there aren't enough resources to go around
- When should you simply buy a faster computer?
 - (Or network link, or expanded highway, or ...)
 - One approach: Buy it when it will pay for itself in improved response time
 - » Perhaps you're paying for worse response time in reduced productivity, customer angst, etc...
 - » Might think that you should buy a faster X when X is utilized 100%, but usually, response time goes to infinity as utilization \Rightarrow 100%
- An interesting implication of this curve:
 - Most scheduling algorithms work fine in the “linear” portion of the load curve, fail otherwise
 - Argues for buying a faster X when hit “knee” of curve

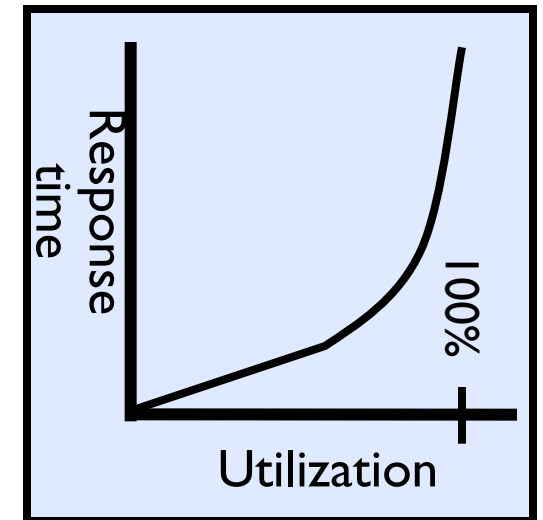

Summary (1 of 2)

- **Scheduling Goals:**
 - Minimize Completion Time (e.g. for human interaction)
 - Maximize Throughput (e.g. for large computations)
 - Fairness (e.g. Proper Sharing of Resources)
 - Predictability (e.g. Hard/Soft Realtime)
- **Round-Robin Scheduling:**
 - Give each thread a small amount of CPU time when it executes; cycle between all ready threads
 - Pros: Better for short jobs
- **Shortest Job First (SJF)/Shortest Remaining Time First (SRTF):**
 - Run whatever job has the least amount of computation to do/least remaining amount of computation to do
- **Lottery Scheduling:**
 - Give each thread a priority-dependent number of tokens (short tasks \Rightarrow more tokens)
- **Multi-Level Feedback Scheduling:**
 - Multiple queues of different priorities and scheduling algorithms
 - Automatic promotion/demotion of process priority in order to approximate SJF/SRTF

Summary (2 of 2)

- **Realtime Schedulers such as EDF**
 - Guaranteed behavior by meeting deadlines
 - Realtime tasks defined by tuple of compute time and period
 - Schedulability test: is it possible to meet deadlines with proposed set of processes?
- **Linux CFS Scheduler: Fair fraction of CPU**
 - Approximates an “ideal” multitasking processor
 - Practical example of “Fair Queueing”