

Operating Systems (Honor Track)

Memory 2: Virtual Memory (Con't), Caching and TLBs

Xin Jin

Spring 2026

Recap: Base and Bound (with Translation)

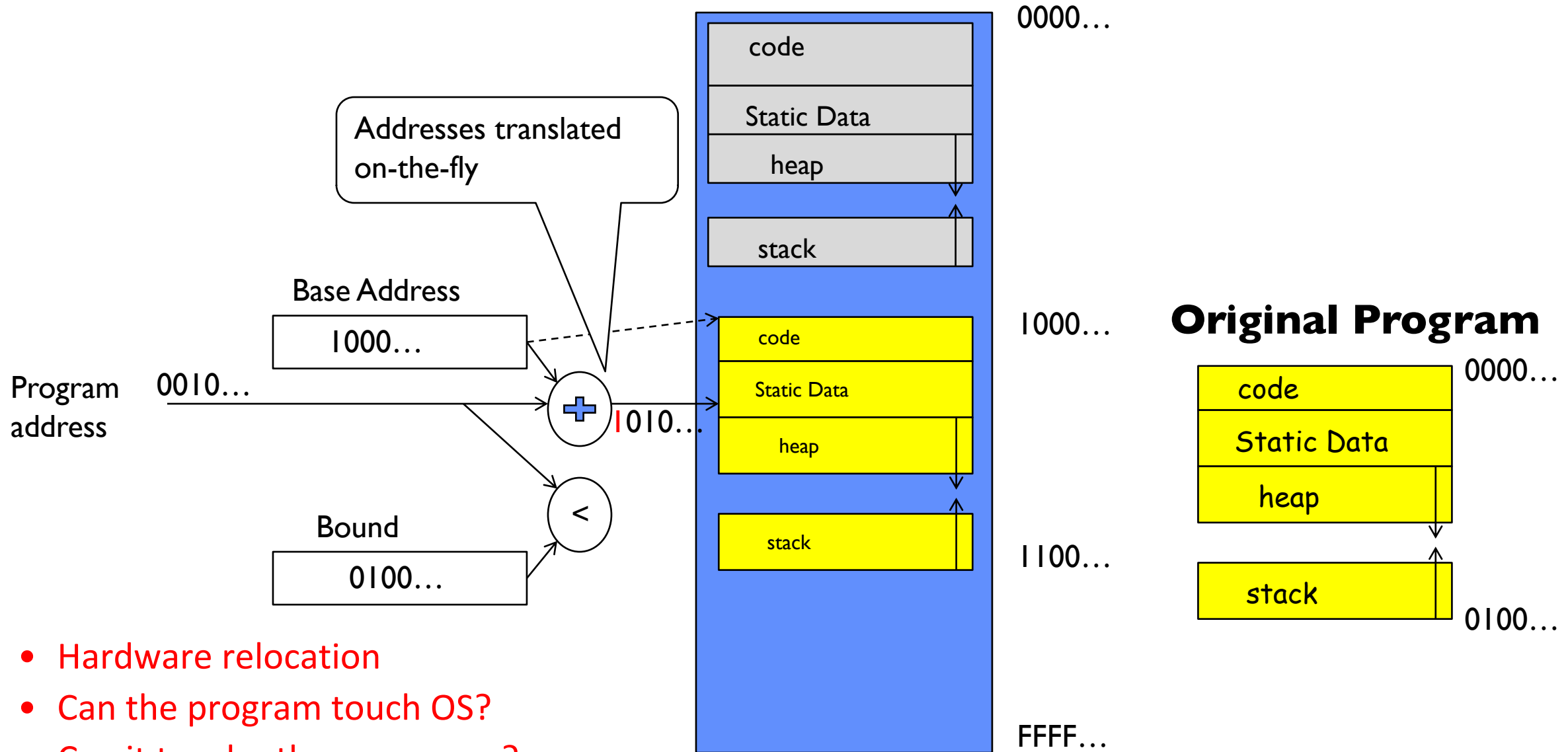

- Hardware relocation
- Can the program touch OS?
- Can it touch other programs?

Recap: Implementation of Multi-Segment Model

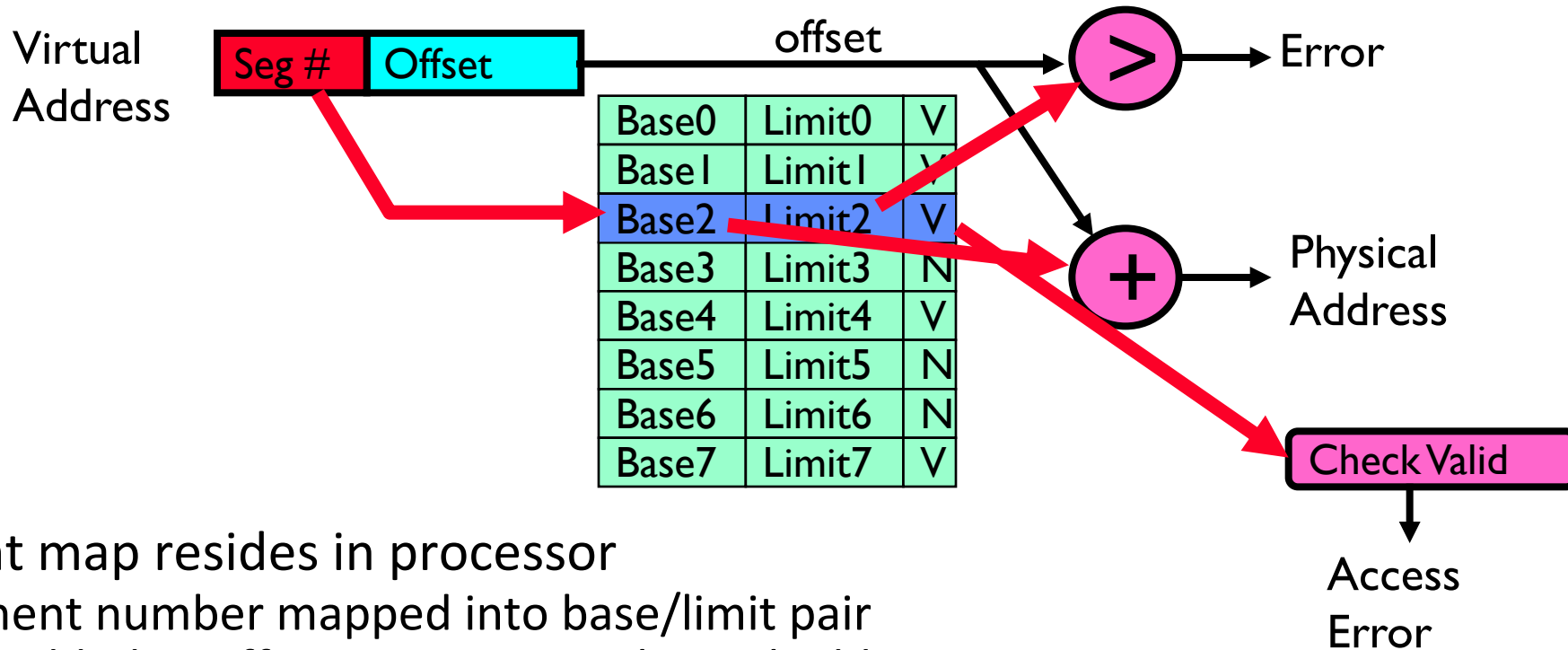

- Segment map resides in processor
 - Segment number mapped into base/limit pair
 - Base added to offset to generate physical address
 - Error check catches offset out of range
- As many chunks of physical memory as entries
 - Segment addressed by portion of virtual address
 - However, could be included in instruction instead:
 - » x86 Example: `mov [es:bx],ax.`
- What is “V/N” (valid / not valid)?
 - Can mark segments as invalid; requires check as well

Recap: How to Implement Simple Paging?

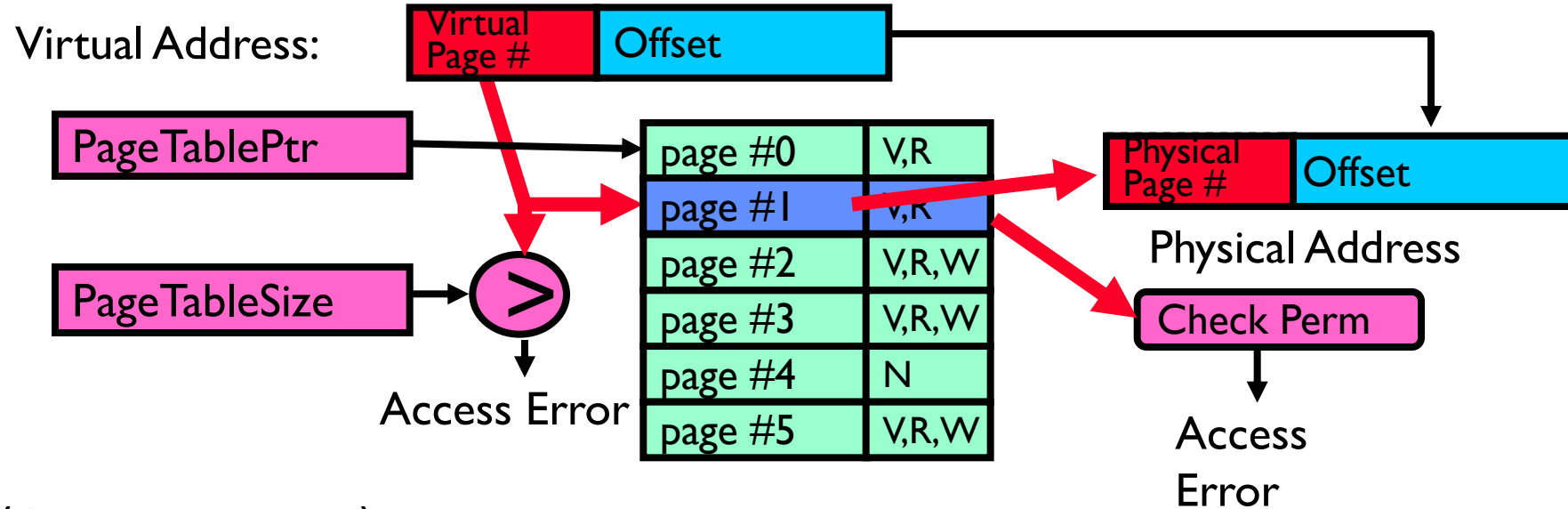

- Page Table (One per process)
 - Resides in physical memory
 - Contains physical page and permission for each virtual page (e.g. Valid bits, Read, Write, etc.)
- Virtual address mapping
 - Offset from Virtual address copied to Physical Address
 - » Example: 10 bit offset \Rightarrow 1024-byte pages
 - Virtual page # is all remaining bits
 - » Example for 32-bits: $32 - 10 = 22$ bits, i.e. 4 million entries
 - » Physical page # copied from table into physical address
 - Check Page Table bounds and permissions

How big do things get?

- 32-bit address space => 2^{32} bytes (**4 GB**)
 - Note: “b” = bit, and “B” = byte
 - And *for memory*:
 - » “K”(kilo) = $2^{10} = 1024$ $\approx 10^3$ (But not quite!): Sometimes called “Ki” (Kibi)
 - » “M”(mega) = $2^{20} = (1024)^2 = 1,048,576$ $\approx 10^6$ (But not quite!): Sometimes called “Mi” (Mibi)
 - » “G”(giga) = $2^{30} = (1024)^3 = 1,073,741,824$ $\approx 10^9$ (But not quite!): Sometimes called “Gi” (Gibi)
- Typical page size: 4 KB
 - how many bits of the address is that ? (remember $2^{10} = 1024$)
 - Ans – $4\text{KB} = 4 \times 2^{10} = 2^{12} \Rightarrow 12$ bits of the address
- **So how big is the simple page table for each process?**
 - $2^{32}/2^{12} = 2^{20}$ (that’s about a million entries) x 4 bytes each => **4 MB**
 - When 32-bit machines got started (vax 11/780, intel 80386), 16 MB was a LOT of memory
- How big is a simple page table on a 64-bit processor (x86_64)?
 - $2^{64}/2^{12} = 2^{52}$ (that’s 4.5×10^{15} or 4.5 exa-entries) x 8 bytes each =
 36×10^{15} bytes or 36 exa-bytes!!!! This is a ridiculous amount of memory!
 - This is really a lot of space – for only the page table!!!
- The address space is *sparse*, i.e. has holes that are not mapped to physical memory
 - So, most of this space is taken up by page tables mapped to nothing

Group Discussion

- Topic: segmentation vs. paging
 - Can you compare segmentation and paging?
 - What are the pros and cons of each approach?
- Discuss in groups of two to three students
 - Each group chooses a leader to summarize the discussion
 - In your group discussion, please do not dominate the discussion, and give everyone a chance to speak

Page Table Discussion

- What needs to be switched on a context switch?
 - Page table pointer and limit
- What provides protection here?
 - Translation (per process) *and* dual-mode!
 - Can't let process alter its own page table!
- Analysis
 - Pros
 - » Simple memory allocation
 - » Easy to share
 - Con: What if address space is sparse?
 - » E.g., on UNIX, code starts at 0, stack starts at $(2^{31}-1)$
 - » With 4KB pages, need 1 million page table entries!
 - Con: What if table really big?
 - » Not all pages used all the time \Rightarrow would be nice to have working set of page table in memory
- Simple Page table is way too big!
 - Does it all need to be in memory?
 - How about multi-level paging?
 - or combining paging and segmentation

How to Structure a Page Table

- Page Table is a *map* (function) from VPN to PPN

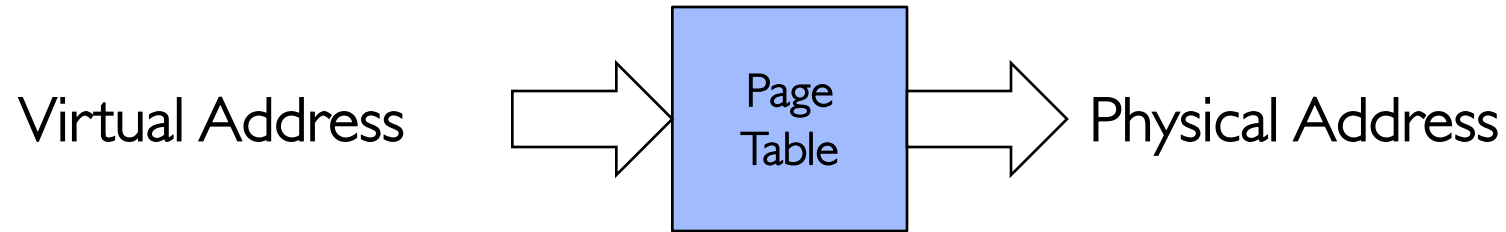

- Simple page table corresponds to a *very large* lookup table
 - VPN is index into table, each entry contains PPN
- What other map structures can you think of?
 - Trees?
 - Hash Tables?

Fix for sparse address space: The two-level page table

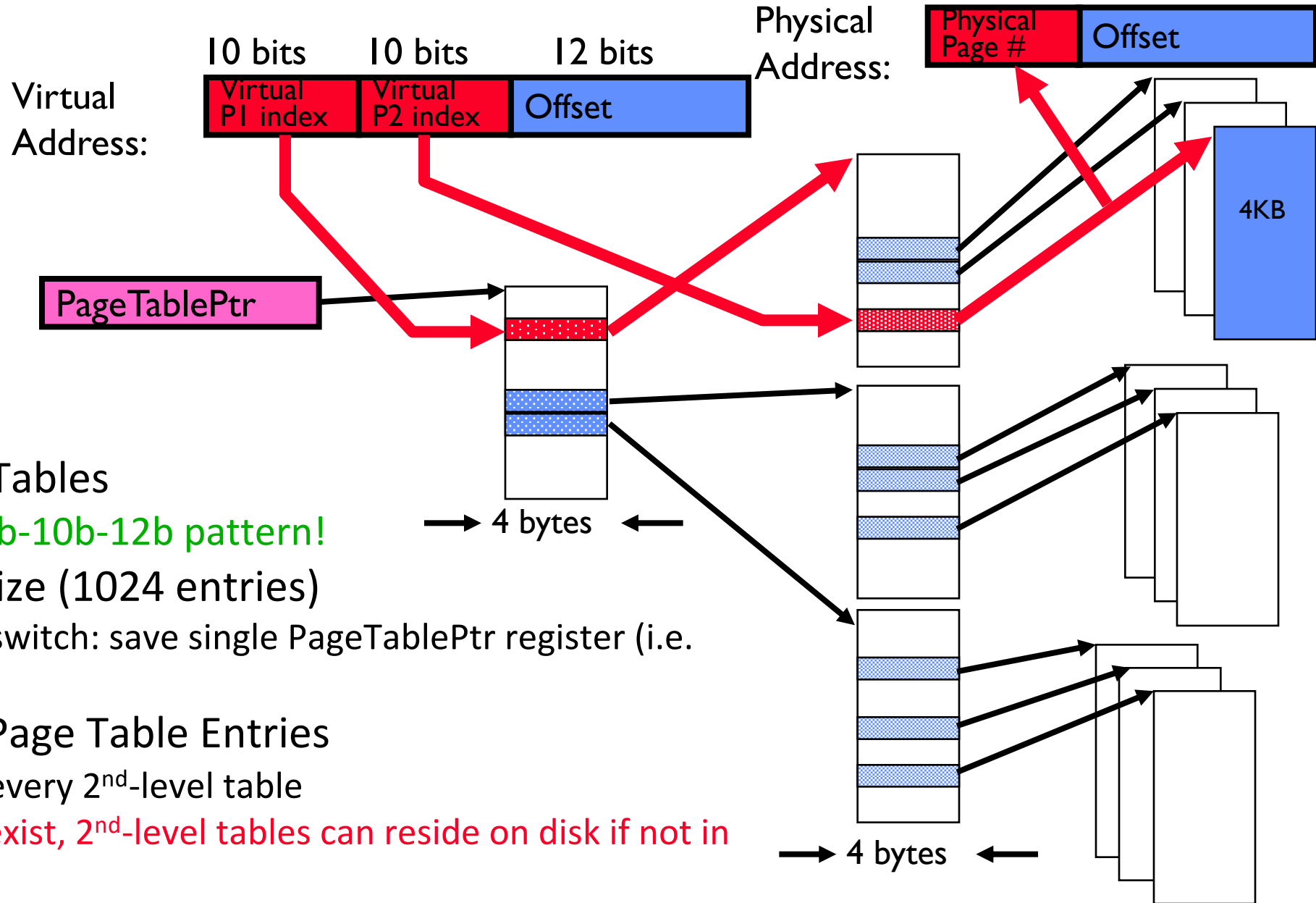

- Tree of Page Tables
 - “Magic” 10b-10b-12b pattern!
- Tables fixed size (1024 entries)
 - On context-switch: save single PageTablePtr register (i.e. CR3)
- Valid bits on Page Table Entries
 - Don't need every 2nd-level table
 - Even when exist, 2nd-level tables can reside on disk if not in use

Page Table Entry (PTE)

- What is in a Page Table Entry (or PTE)?
 - Pointer to next-level page table or to actual page
 - Flags: valid, read-only, read-write, write-only, etc.
- How do we use the PTE?
 - Invalid PTE can imply different things:
 - » Region of address space is actually invalid or
 - » Page/directory is just somewhere else than memory
 - Validity checked first
 - » OS can use other bits for location info

Page Table Entry (PTE)

- Usage Example: **Demand Paging**
 - Keep only active pages in memory
 - Place others on disk and mark their PTEs invalid
- Usage Example: **Copy on Write**
 - UNIX fork gives *copy* of parent address space to child
 - » Address spaces disconnected after child created
 - How to do this cheaply?
 - » Make copy of parent's page tables (point at same memory)
 - » Mark entries in both sets of page tables as read-only
 - » Page fault on write creates two copies
- Usage Example: **Zero Fill On Demand**
 - New data pages must carry no information (say be zeroed)
 - Mark PTEs as invalid; page fault on use gets zeroed page
 - Often, OS creates zeroed pages in background

Sharing with multilevel page tables

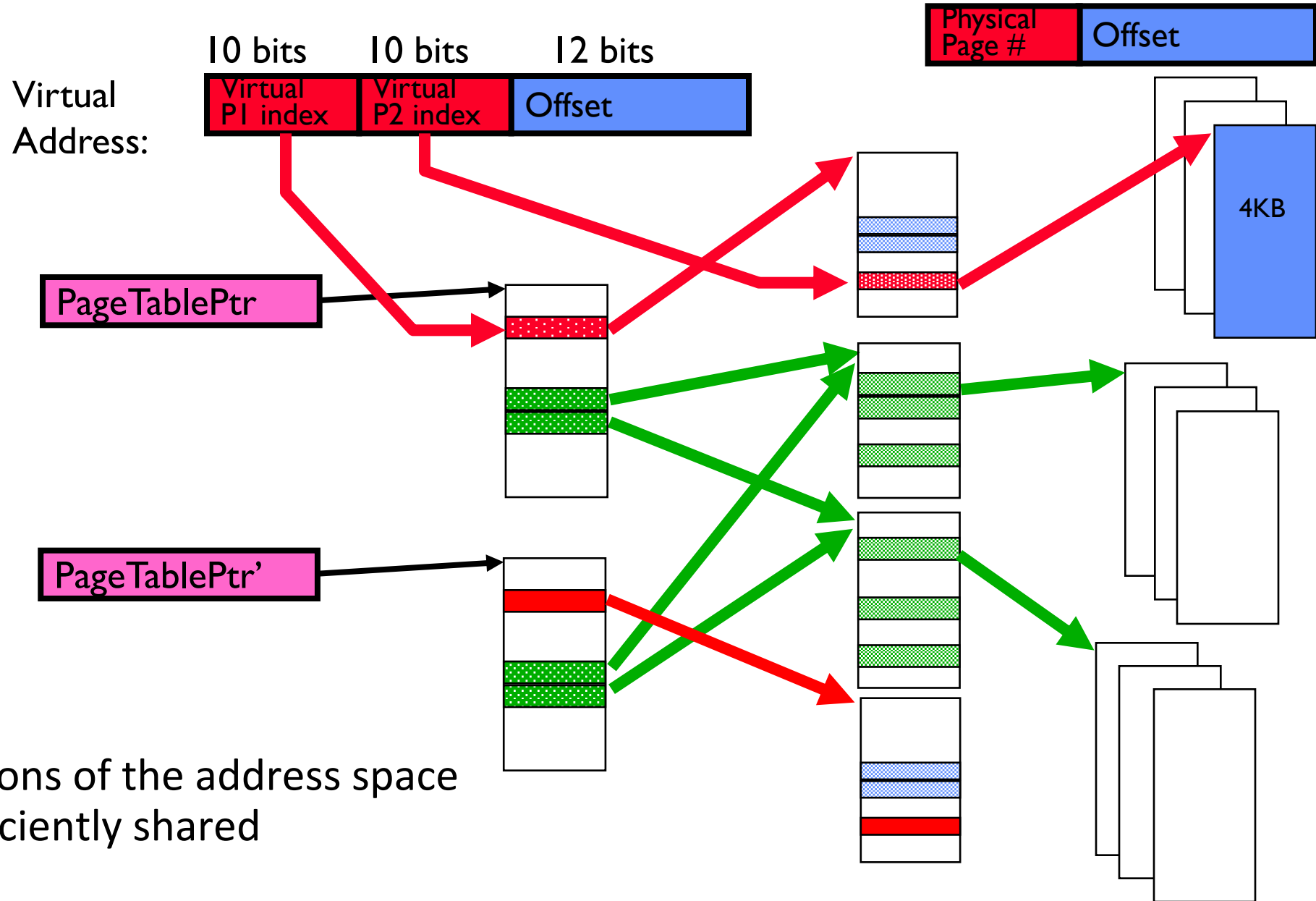

- Entire regions of the address space can be efficiently shared

Summary: Two-Level Paging

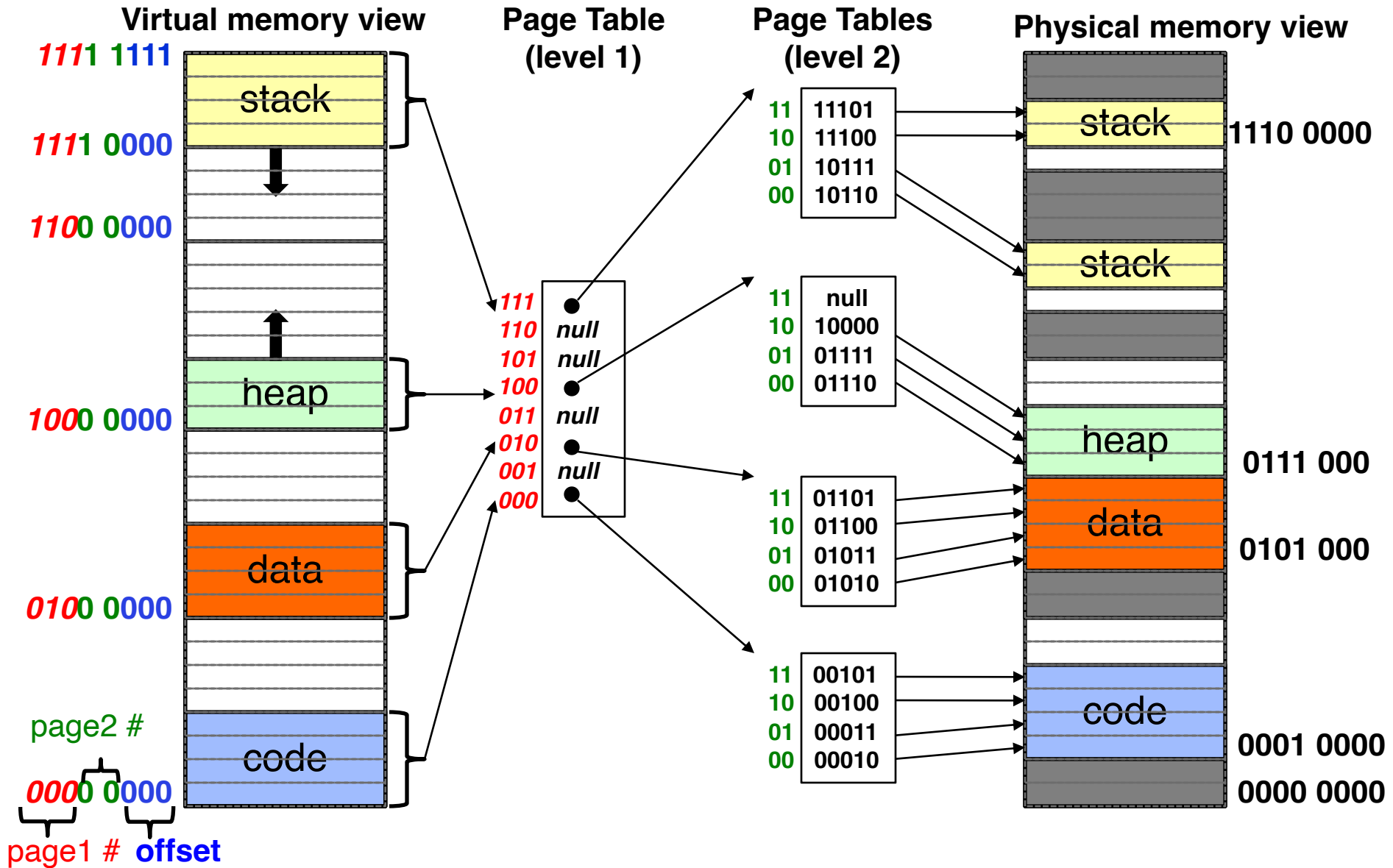

Summary: Two-Level Paging

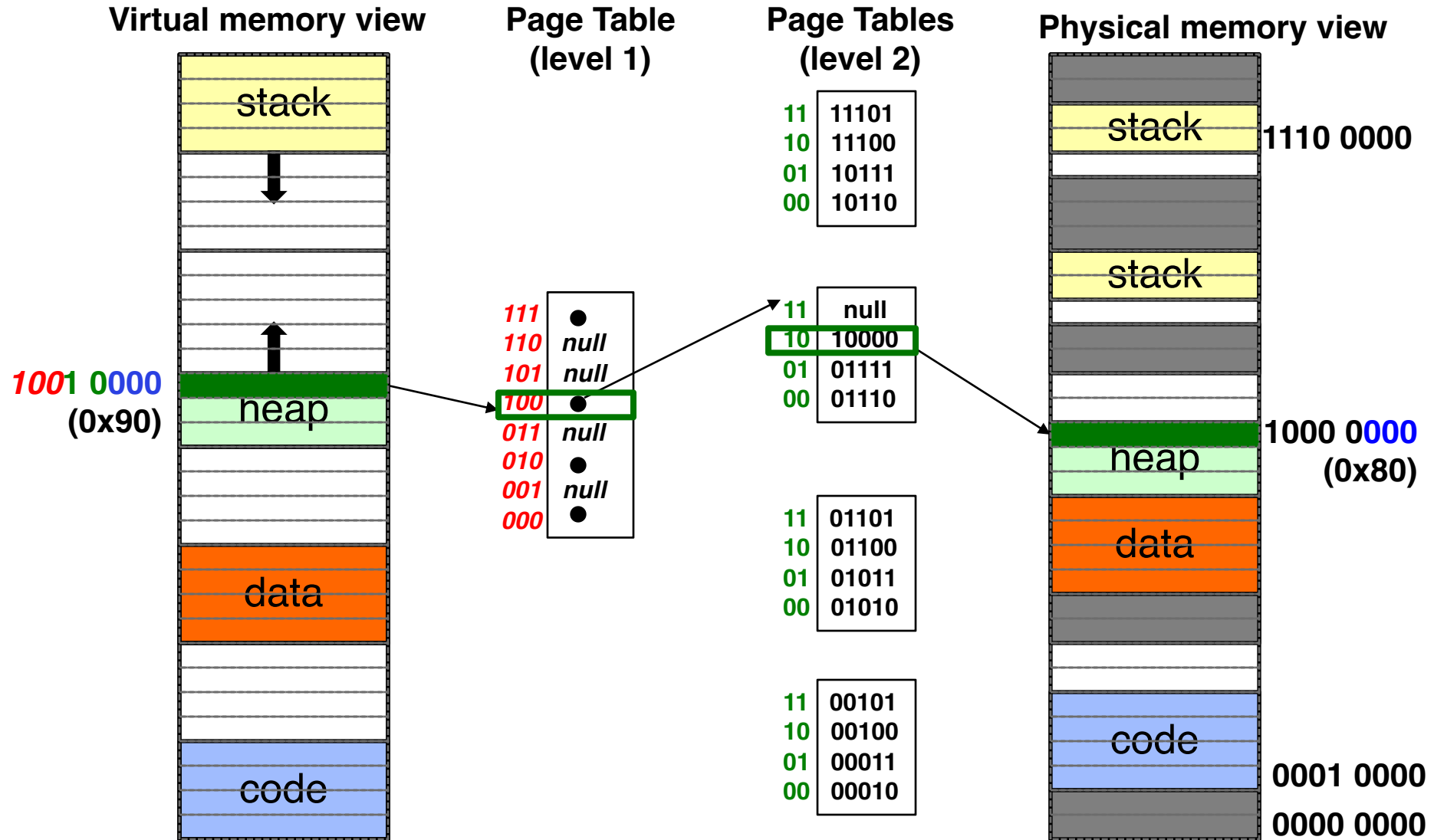

Multi-level Translation: Segments + Pages

- What about a tree of tables?
 - Lowest level page table \Rightarrow memory still allocated with bitmap
 - Higher levels often segmented
- Could have any number of levels. Example (top segment):

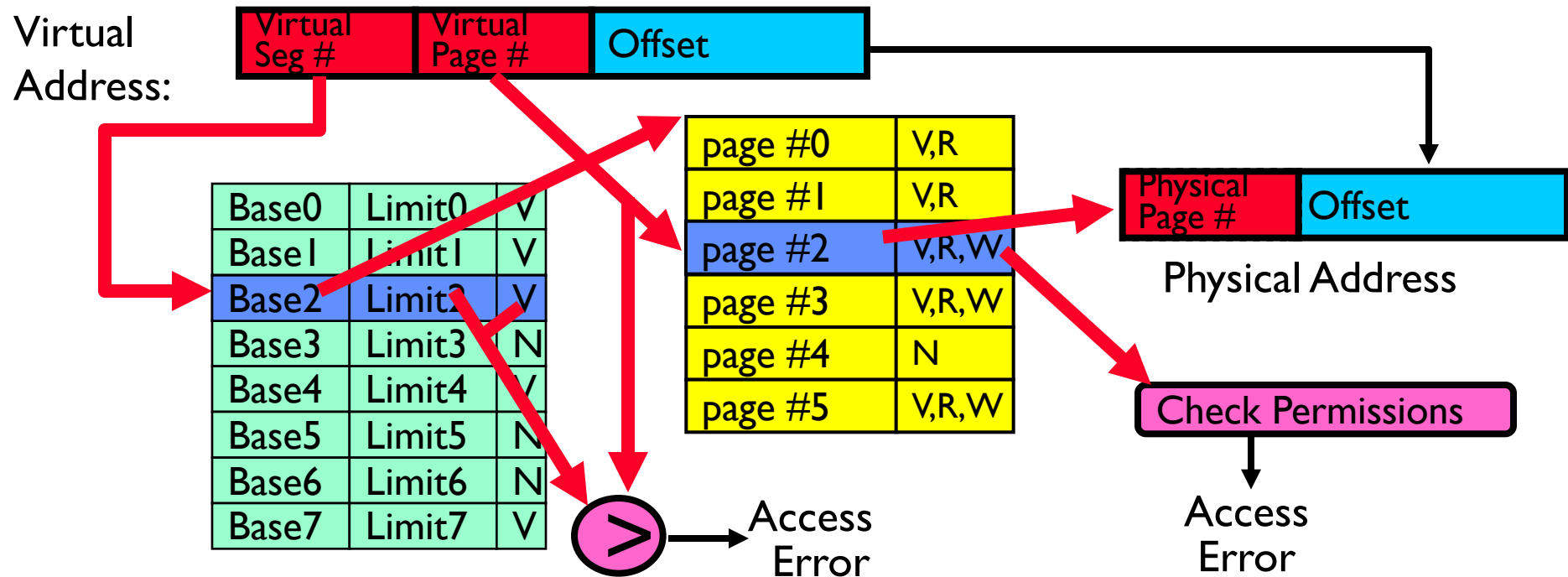

- What must be saved/restored on context switch?
 - Contents of top-level segment registers (for this example)
 - Pointer to top-level table (page table)

What about Sharing (Complete Segment)?

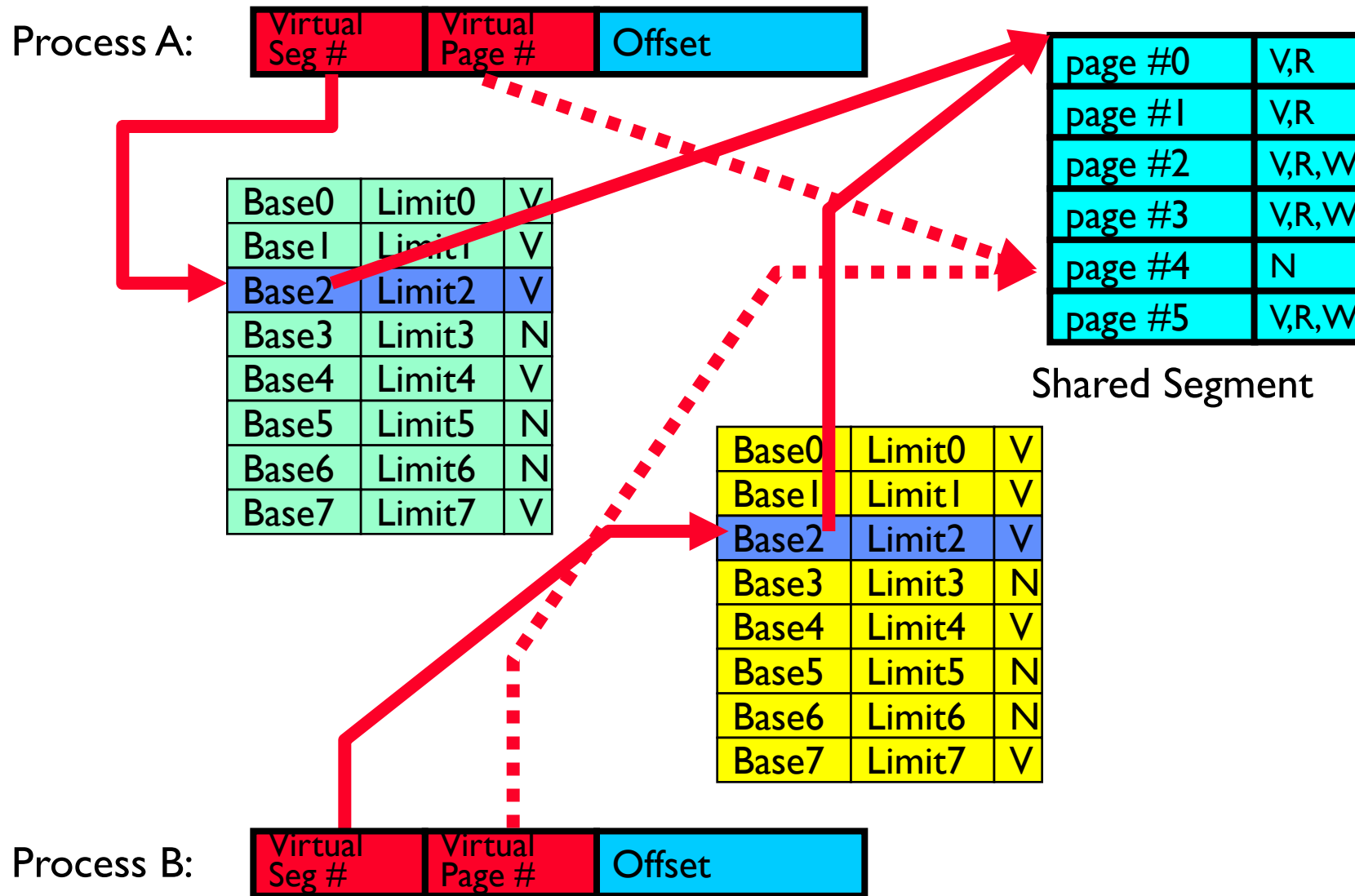

X86_64: Four-level page table!

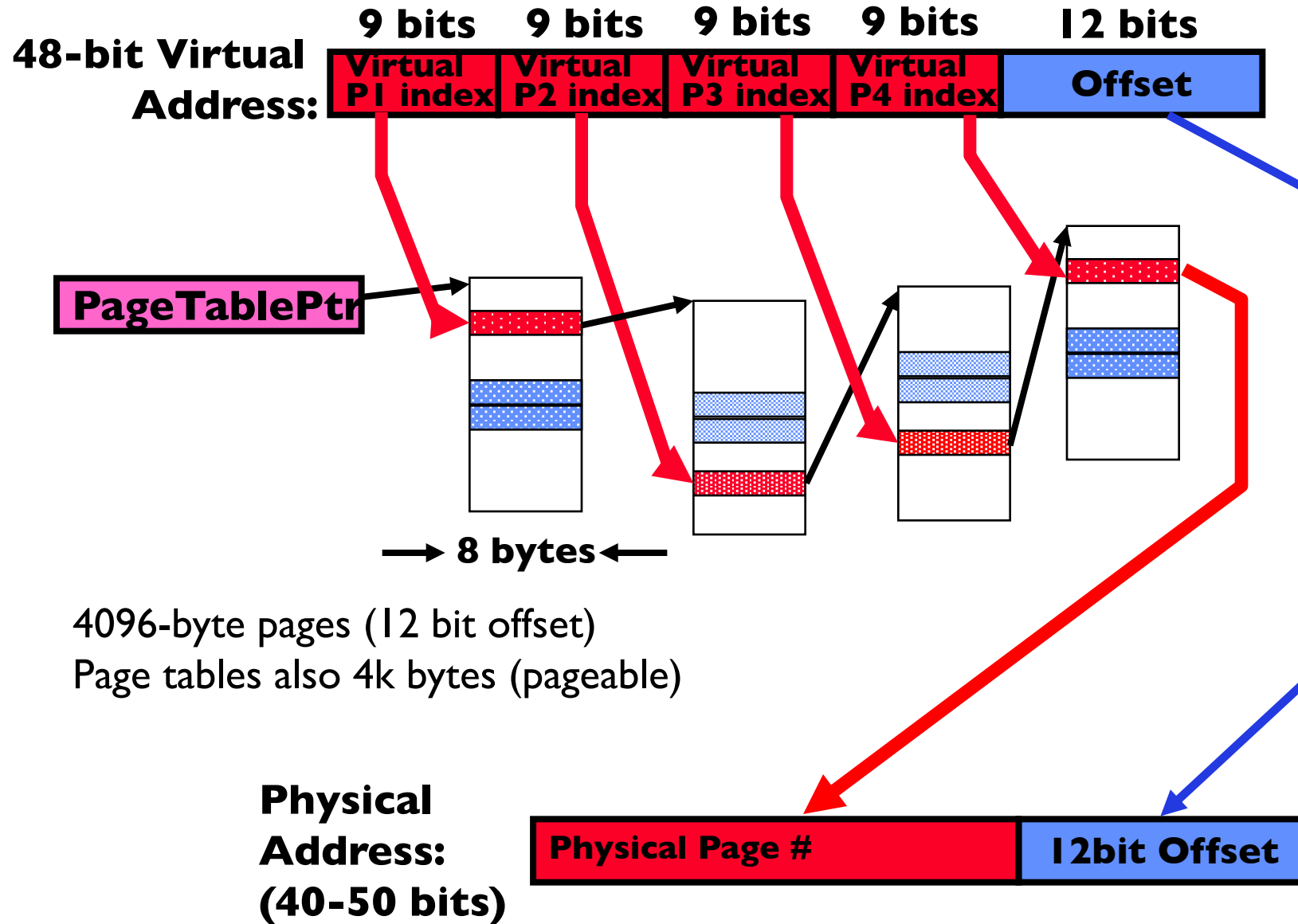

IA64: 64bit addresses: Six-level page table?!?

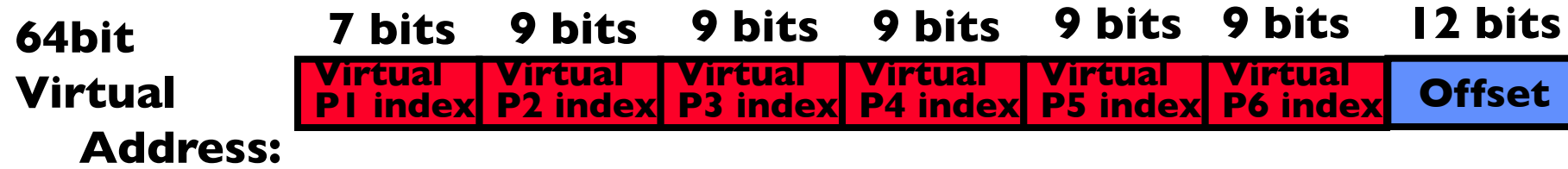

No!

Too slow

Too many almost-empty tables

Group Discussion

- Topic: multi-level translation
 - What are the pros and cons of multi-level translation?
- Discuss in groups of two to three students
 - Each group chooses a leader to summarize the discussion
 - In your group discussion, please do not dominate the discussion, and give everyone a chance to speak

Multi-level Translation Analysis

- Pros:
 - Only need to allocate as many page table entries as we need for application
 - » In other words, sparse address spaces are easy
 - Easy memory allocation
 - Easy Sharing
 - » Share at segment or page level (need additional reference counting)
- Cons:
 - One pointer per page (typically 4K – 16K pages today)
 - Page tables need to be contiguous
 - » However, the 10b-10b-12b configuration keeps tables to exactly one page in size
 - Two (or more, if >2 levels) lookups per reference
 - » Seems very expensive!

Recall: Dual-Mode Operation

- Can a process modify its own translation tables? **NO!**
 - If it could, could get access to all of physical memory (no protection!)
- To Assist with Protection, **Hardware** provides at least two modes (Dual-Mode Operation):
 - “Kernel” mode (or “supervisor” or “protected”)
 - “User” mode (Normal program mode)
 - Mode set with bit(s) in control register only accessible in Kernel mode
 - Kernel can easily switch to user mode; User program must invoke an exception of some sort to get back to kernel mode
- Note that x86 model actually has more modes:
 - Traditionally, four “rings” representing priority; most OSes use only two:
 - » Ring 0 \Rightarrow Kernel mode, Ring 3 \Rightarrow User mode
 - » Called “Current Privilege Level” or CPL
 - Newer processors have additional mode for hypervisor (“Ring -1”)
- **Certain operations restricted to Kernel mode:**
 - **Modifying page table base, and segment descriptor tables**
 - » **Have to transition into Kernel mode before you can change them!**
 - **Also, all page-table pages must be mapped only in kernel mode**

Alternative: Inverted Page Table

- With all previous examples (“Forward Page Tables”)
 - Size of page table is at least as large as amount of virtual memory allocated to processes
 - Physical memory may be much less
 - » Much of process space may be out on disk or not in use

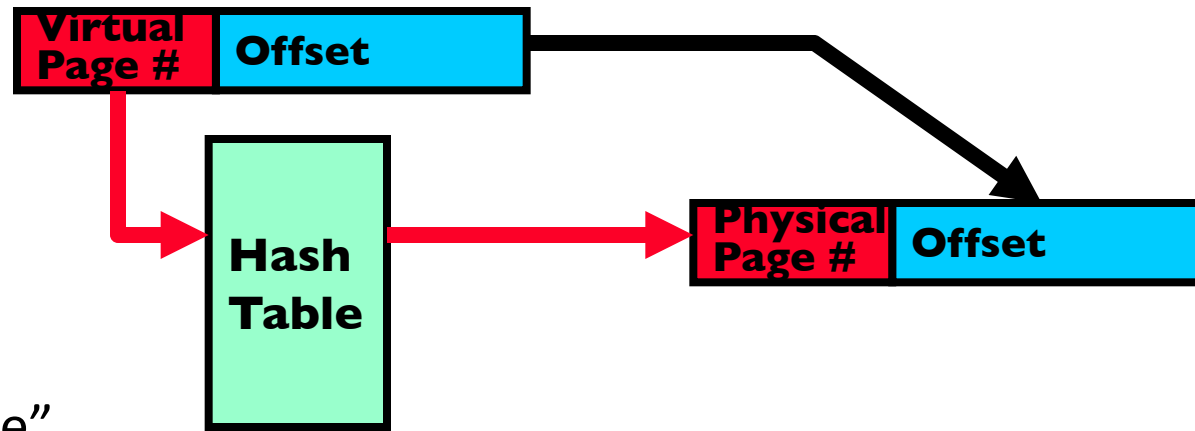

- Answer: use a hash table
 - Called an “Inverted Page Table”
 - Size is independent of virtual address space
 - Directly related to amount of physical memory
 - Very attractive option for 64-bit address spaces
 - » PowerPC, UltraSPARC, IA64
- Cons:
 - Complexity of managing hash chains: Often in hardware!
 - Poor cache locality of page table

Group Discussion

- Topic: simple segmentation, paging (single-level), paged segmentation, multi-level paging, inverted page tables
 - What are the pros and cons of each solution?
- Discuss in groups of two to three students
 - Each group chooses a leader to summarize the discussion
 - In your group discussion, please do not dominate the discussion, and give everyone a chance to speak

Address Translation Comparison

	Advantages	Disadvantages
Simple Segmentation	Fast context switching (segment map maintained by CPU)	Internal/External fragmentation
Paging (Single-Level)	No external fragmentation Fast and easy allocation	Large table size (~ virtual memory) Internal fragmentation
Paged Segmentation	Table size ~ # of pages in virtual memory	Multiple memory references per page access
Multi-Level Paging	Fast and easy allocation	
Inverted Page Table	Table size ~ # of pages in physical memory	Hash function more complex No cache locality of page table

How is the Translation Accomplished?

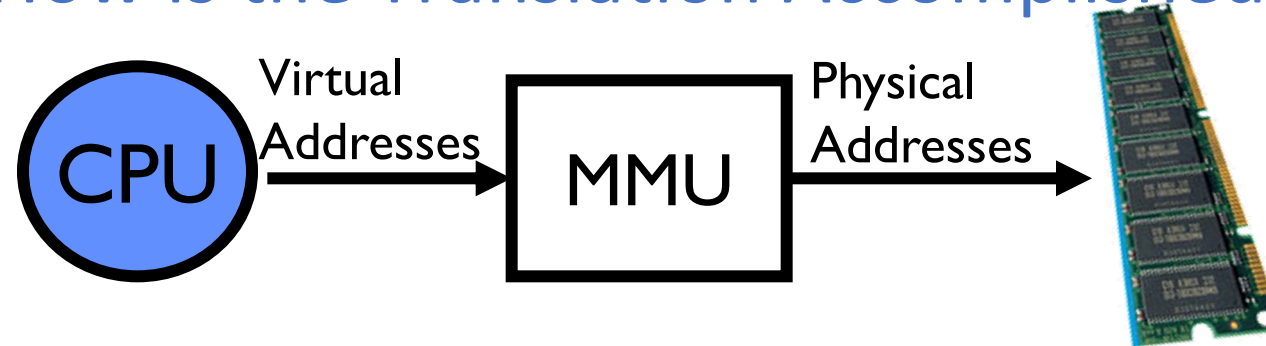

- The MMU must translate virtual address to physical address on:
 - Every instruction fetch
 - Every load
 - Every store
- What does the MMU need to do to translate an address?
 - 1-level Page Table
 - » Read PTE from memory, check valid, merge address
 - » Set “accessed” bit in PTE, Set “dirty bit” on write
 - 2-level Page Table
 - » Read and check first level
 - » Read, check, and update PTE
 - N-level Page Table ...
- MMU does *page table Tree Traversal* to translate each address

Where and What is the MMU ?

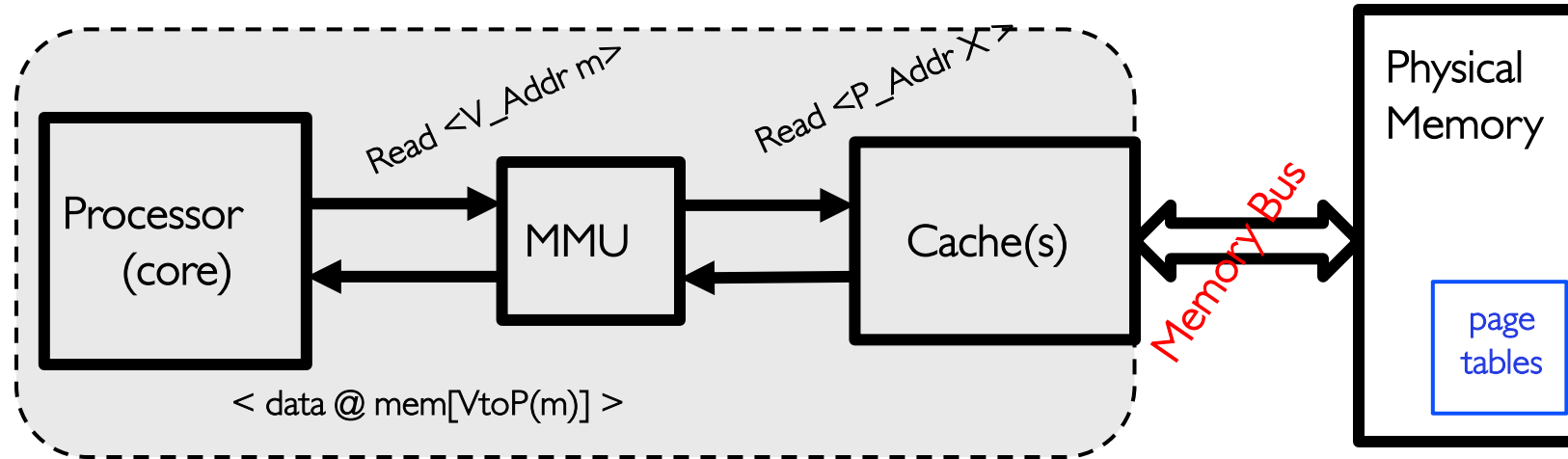

- The processor requests READ Virtual-Address to memory system
 - Through the MMU to the cache (to the memory)
- Some time later, the memory system responds with the data stored at the physical address (resulting from virtual \rightarrow physical) translation
 - Fast on a cache hit, slow on a miss
- So what is the MMU doing?
- On every reference (I-fetch, Load, Store) read (multiple levels of) page table entries to get physical frame or FAULT
 - Through the caches to the memory
 - Then read/write the physical location

ICS: Caching Concept

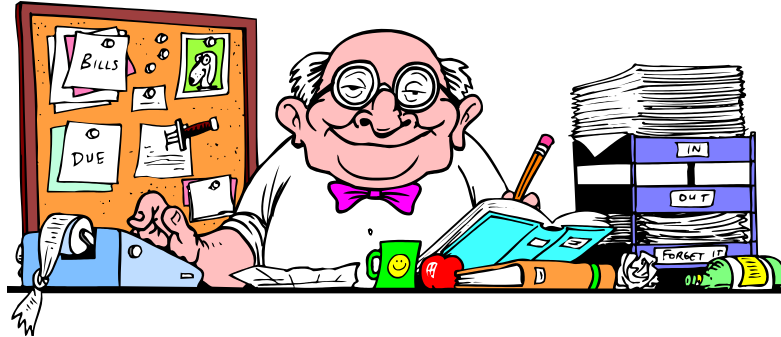

- **Cache**: a repository for copies that can be accessed more quickly than the original
 - Make frequent case fast and infrequent case less dominant
- Caching underlies many techniques used today to make computers fast
 - Can cache: memory locations, address translations, pages, file blocks, file names, network routes, etc...
- Only good if:
 - Frequent case frequent enough
 - Infrequent case not too expensive
- Important measure: Average Access time =
(Hit Rate x **Hit Time**) + (Miss Rate x **Miss Time**)

ICS: In Machine Structures...

- Caching is the key to memory system performance

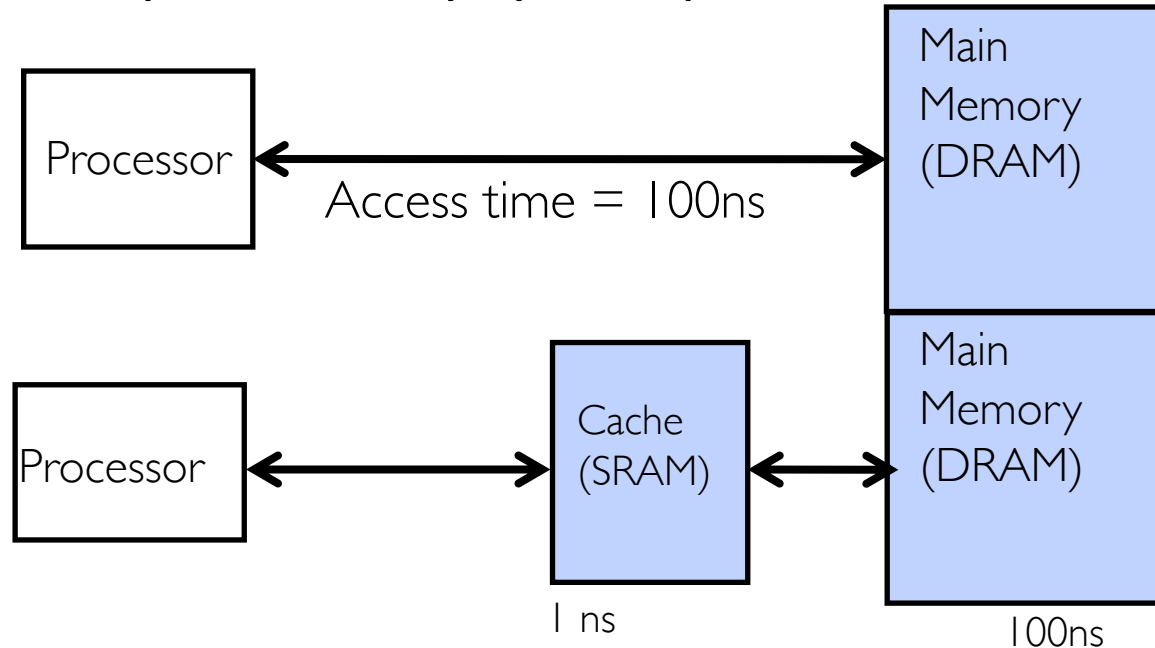

Average Memory Access Time (AMAT)

$$= (\text{Hit Rate} \times \text{HitTime}) + (\text{Miss Rate} \times \text{MissTime})$$

Where HitRate + MissRate = 1

$$\text{HitRate} = 90\% \Rightarrow \text{AMAT} = (0.9 \times 1) + (0.1 \times 101) = 11 \text{ ns}$$

$$\text{HitRate} = 99\% \Rightarrow \text{AMAT} = (0.99 \times 1) + (0.01 \times 101) = 2 \text{ ns}$$

Another Major Reason to Deal with Caching

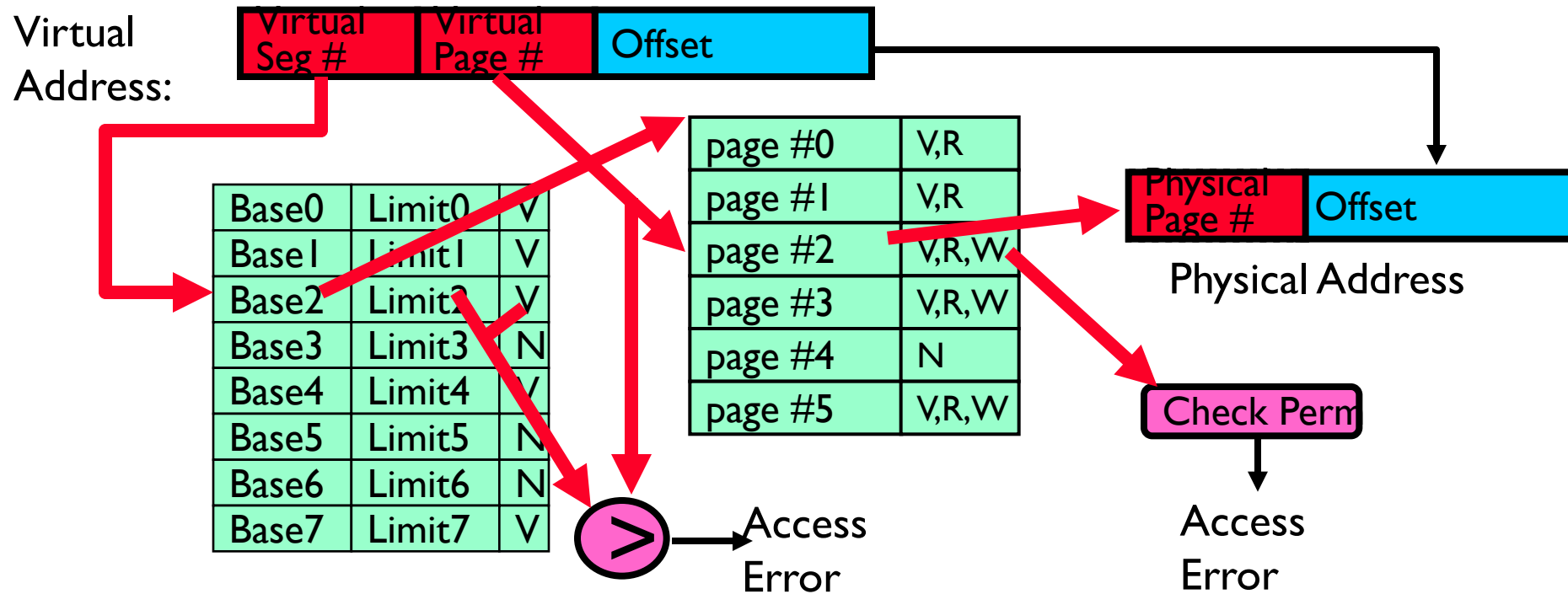

- Cannot afford to translate on every access
 - At least three DRAM accesses per actual DRAM access
 - Or: perhaps I/O if page table partially on disk!
- Solution? Cache translations!
 - Translation Cache: TLB (“Translation Lookaside Buffer”)

Why Does Caching Help? Locality!

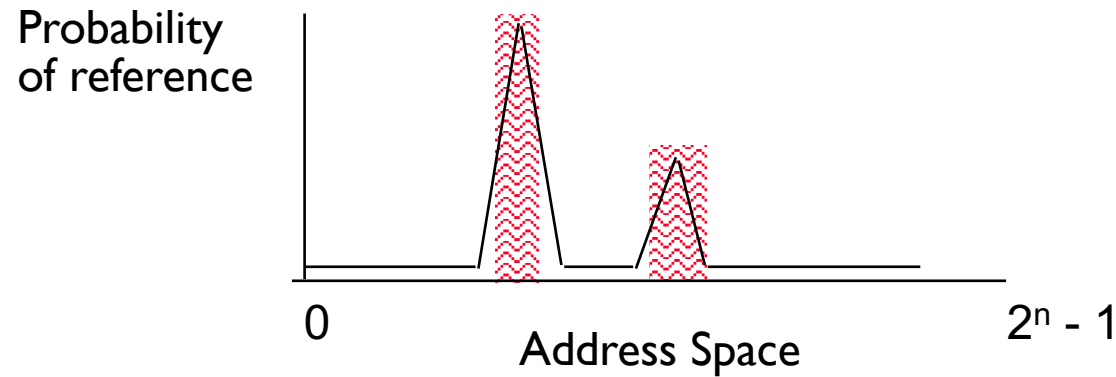

- **Temporal Locality** (Locality in Time):
 - Keep recently accessed data items closer to processor
- **Spatial Locality** (Locality in Space):
 - Move contiguous blocks to the upper levels

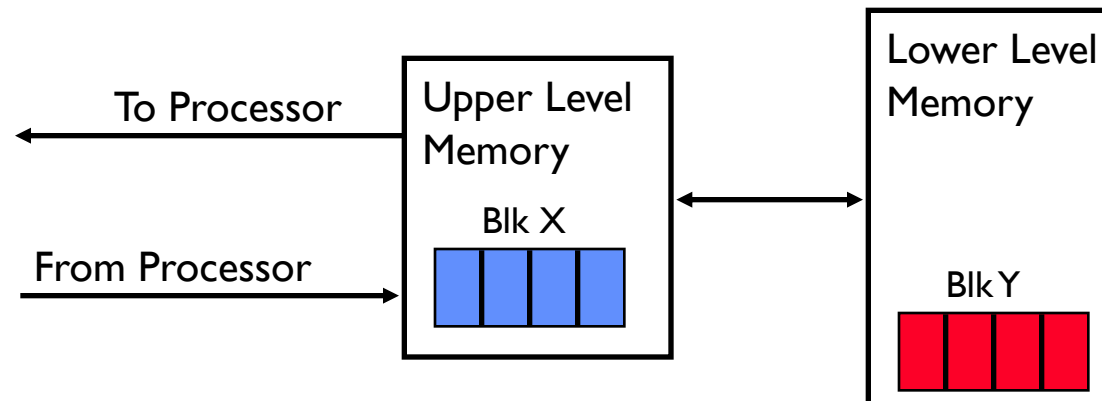

Recall: Memory Hierarchy

- Caching: Take advantage of the principle of locality to:
 - Present the illusion of having as much memory as in the cheapest technology
 - Provide average speed similar to that offered by the fastest technology

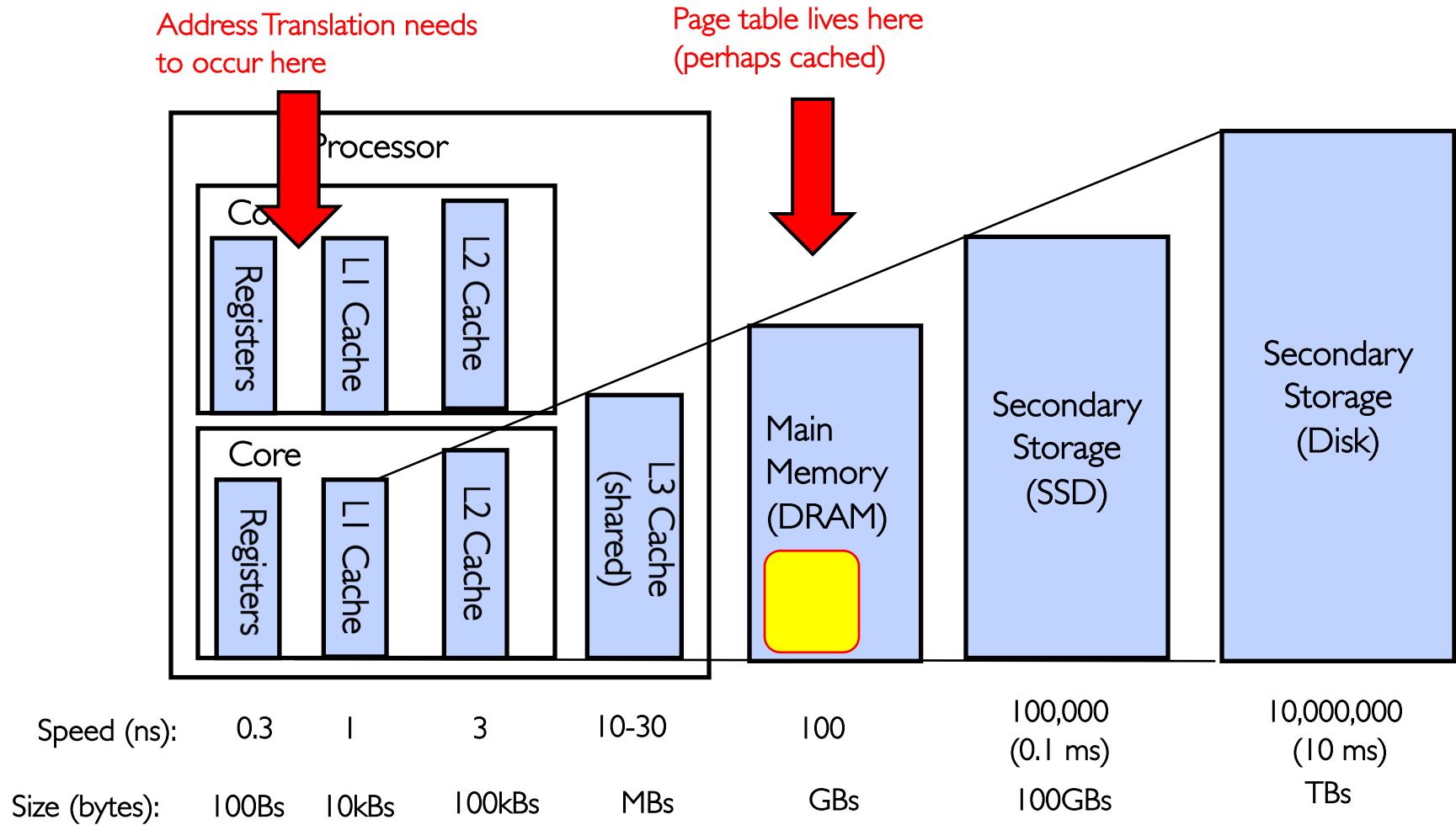

How do we make Address Translation Fast?

- Cache results of recent translations !
 - Different from a traditional cache
 - Cache Page Table Entries using Virtual Page # as the key

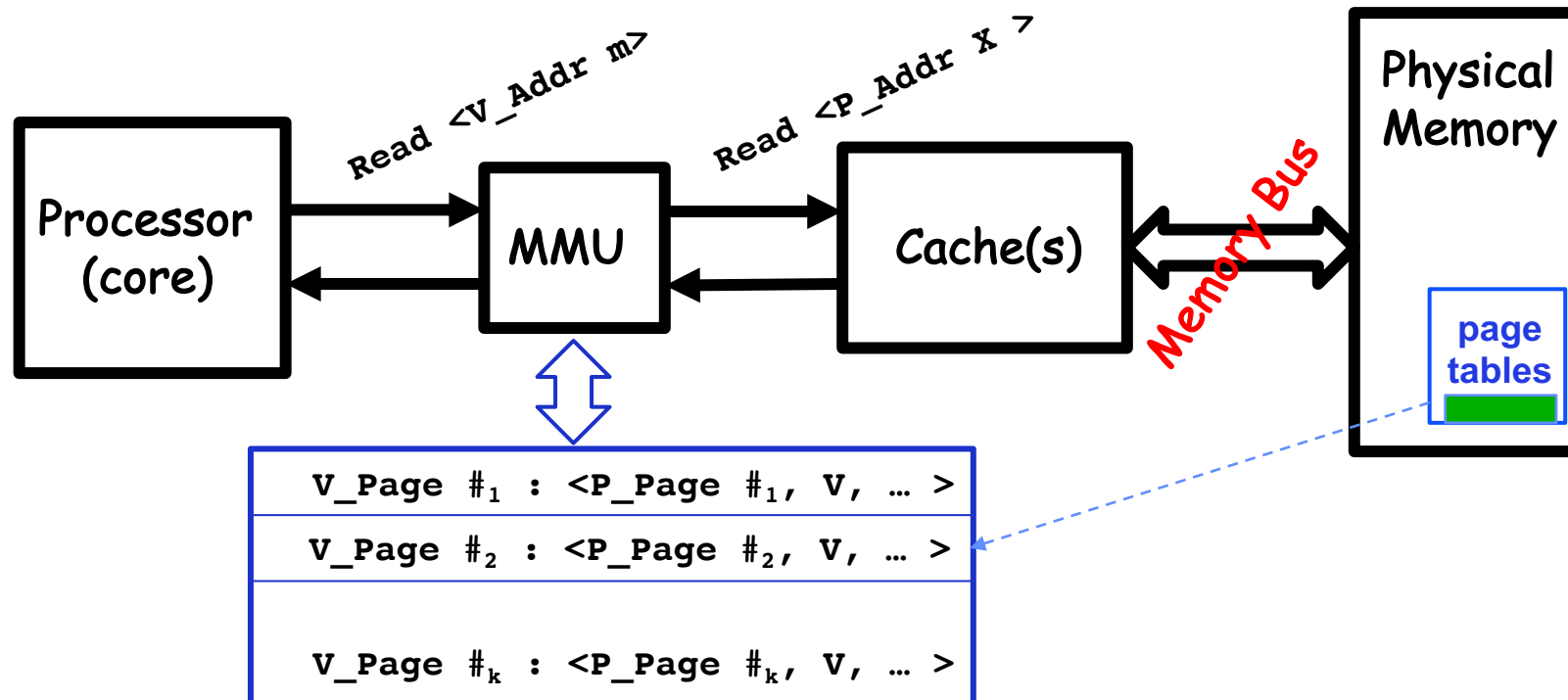

Translation Look-Aside Buffer

- Record recent Virtual Page # to Physical Page # translation
- If present, have the physical address without reading any of the page tables !!!
 - Even if the translation involved multiple levels
 - Caches the end-to-end result
- Was invented by Sir Maurice Wilkes – *prior to caches*
 - When you come up with a new concept, you get to name it!
- On a *TLB miss*, the page tables may be cached, so only go to memory when both miss

Caching Applied to Address Translation

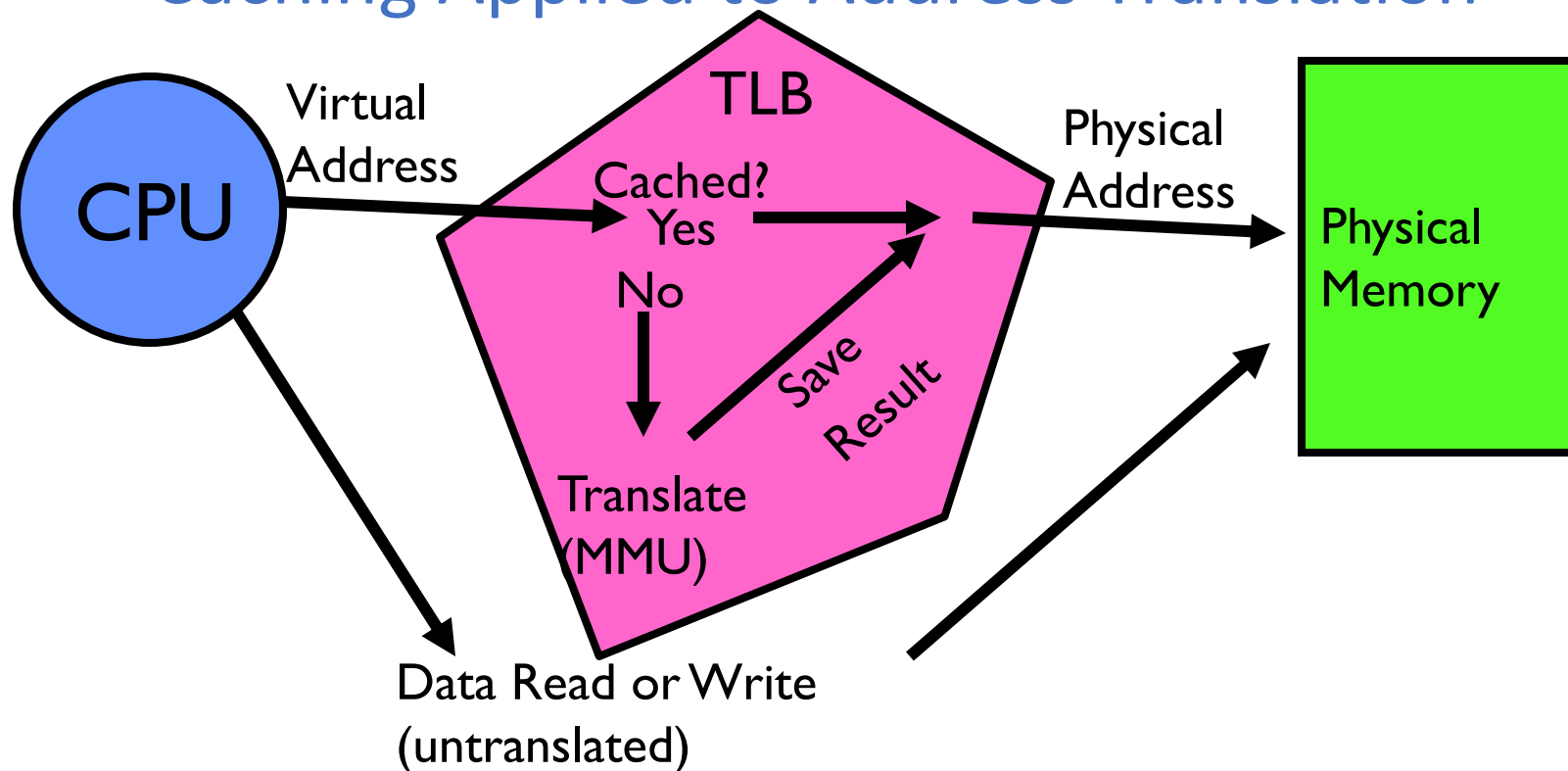

- Question is one of page locality: does it exist?
 - Instruction accesses spend a lot of time on the same page (since accesses sequential)
 - Stack accesses have definite locality of reference
 - Data accesses have less page locality, but still some...
- Can we have a TLB hierarchy?
 - Sure: multiple levels at different sizes/speeds

A Summary on Sources of Cache Misses

- **Compulsory** (cold start, first reference): first access to a block
 - “Cold” fact of life: not a whole lot you can do about it
 - Note: If you are going to run “billions” of instruction, Compulsory Misses are insignificant
- **Capacity**:
 - Cache cannot contain all blocks access by the program
 - Solution: increase cache size
- **Conflict** (collision):
 - Multiple memory locations mapped to the same cache location
 - Solution 1: increase cache size
 - Solution 2: increase associativity
- **Coherence** (Invalidation): other process (e.g., I/O) updates memory

How is a Block found in a Cache?

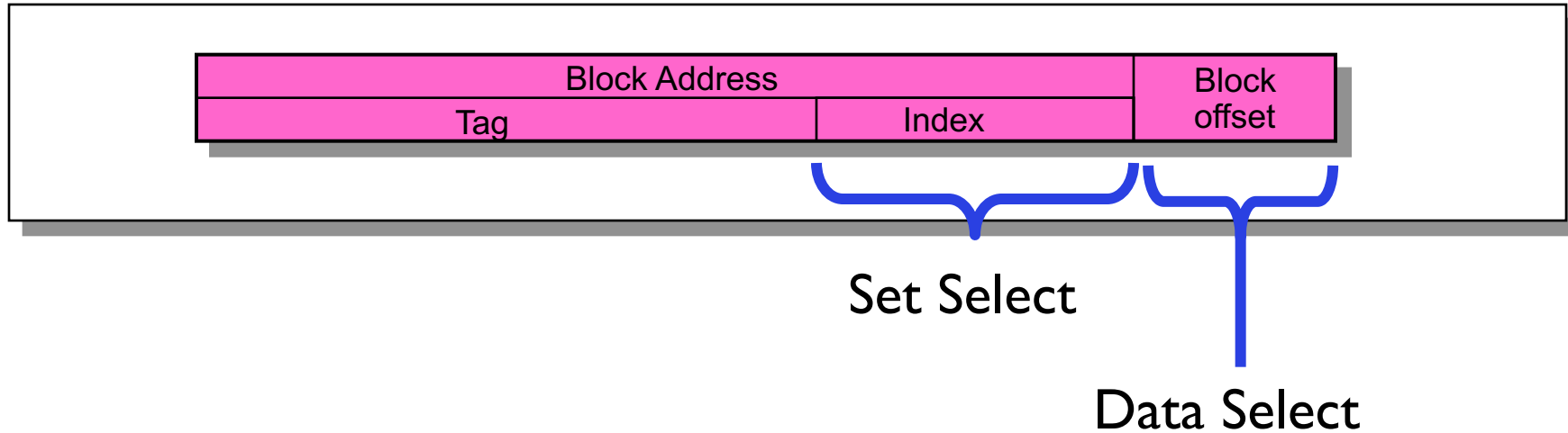

- **Block** is minimum quantum of caching
 - Data select field used to select data within block
 - Many caching applications don't have data select field
- **Index** Used to Lookup Candidates in Cache
 - Index identifies the set
- **Tag** used to identify actual copy
 - If no candidates match, then declare cache miss

Review: Direct Mapped Cache

- **Direct Mapped 2^N byte cache:**
 - The uppermost (32 - N) bits are always the Cache Tag
 - The lowest M bits are the Byte Select (Block Size = 2^M)
- Example: 1 KB Direct Mapped Cache with 32 B Blocks
 - Index chooses potential block
 - Tag checked to verify block
 - Byte select chooses byte within block

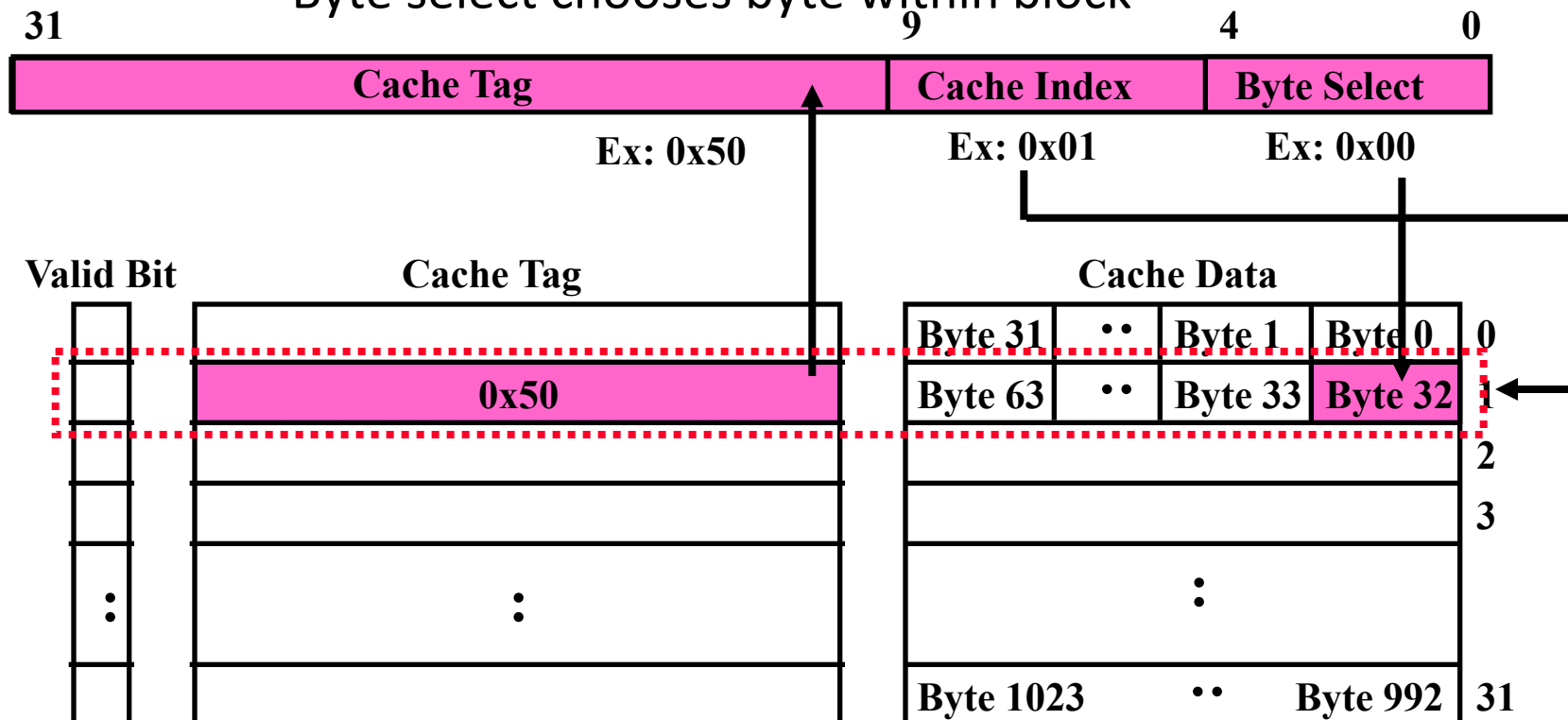

Review: Set Associative Cache

- **N-way set associative**: N entries per Cache Index
 - N direct mapped caches operates in parallel
- Example: Two-way set associative cache
 - Cache Index selects a “set” from the cache
 - Two tags in the set are compared to input in parallel
 - Data is selected based on the tag result

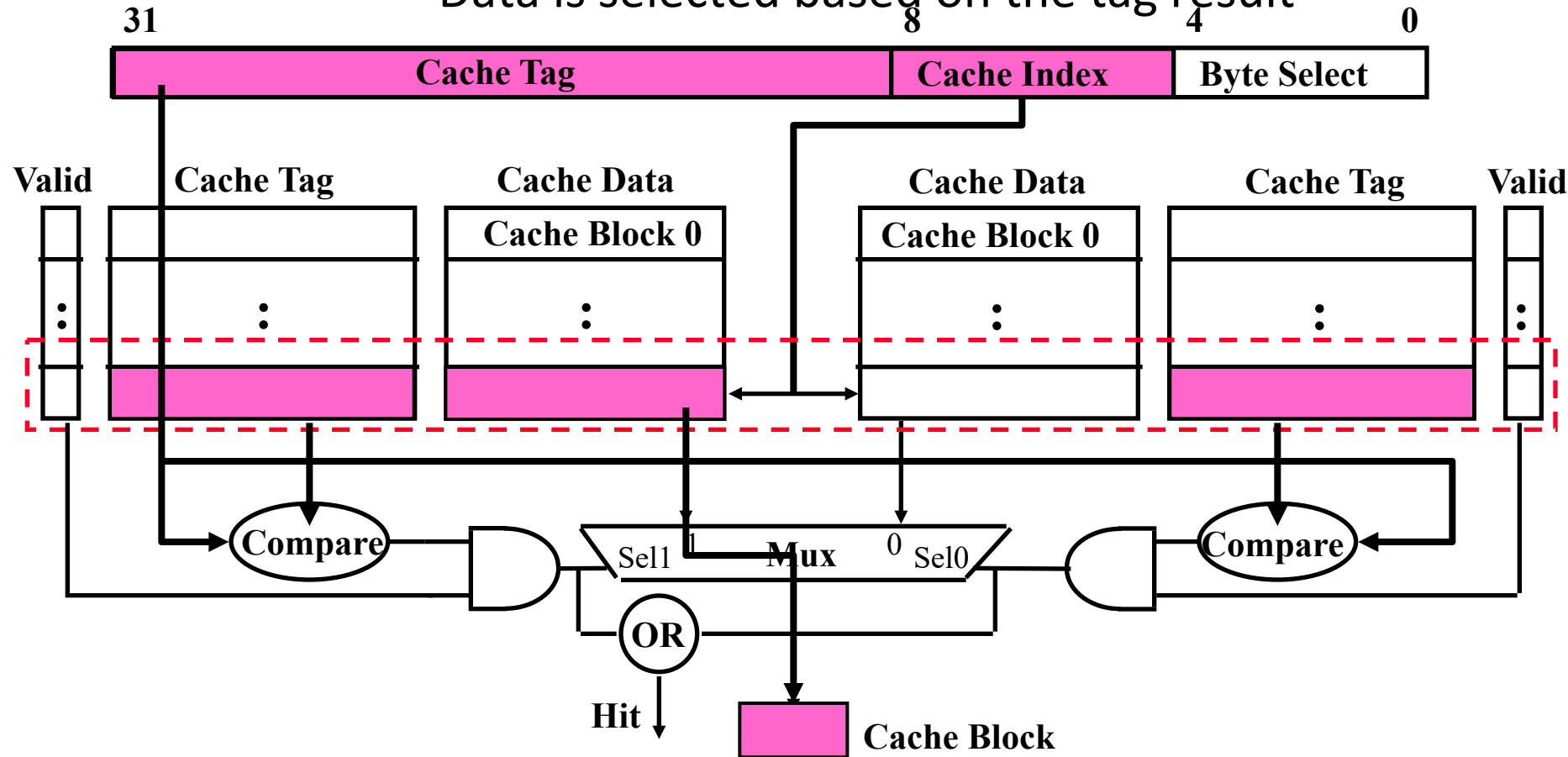

Review: Fully Associative Cache

- **Fully Associative**: Every block can hold any line
 - Address does not include a cache index
 - Compare Cache Tags of all Cache Entries in Parallel
- Example: Block Size=32B blocks
 - We need N 27-bit comparators
 - Still have byte select to choose from within block

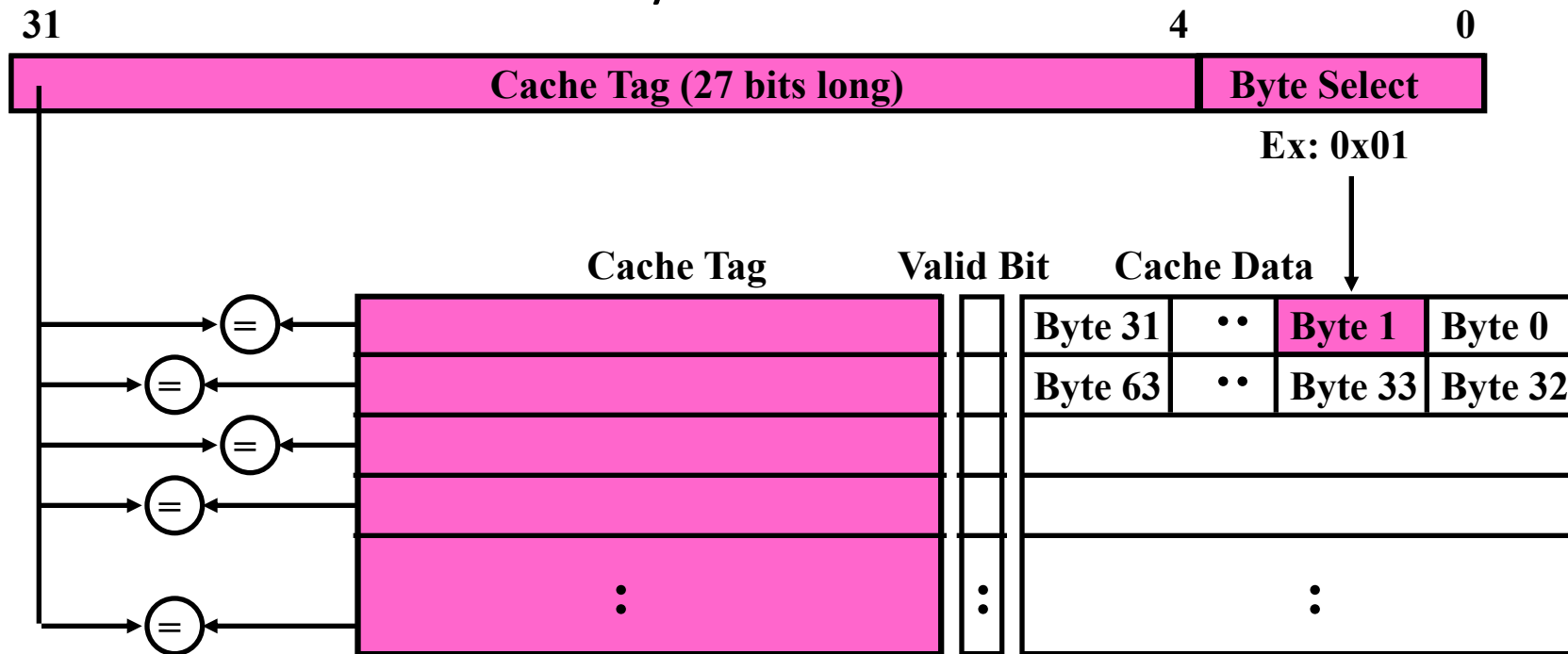

Where does a Block Get Placed in a Cache?

- Example: Block 12 placed in 8 block cache

Direct mapped:

block 12 can go
only into block 4
($12 \bmod 8$)

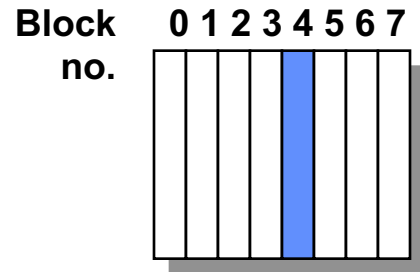

Set associative:

block 12 can go
anywhere in set 0
($12 \bmod 4$)

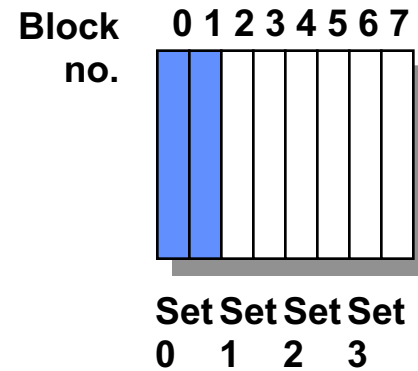

Fully associative:

block 12 can go
anywhere

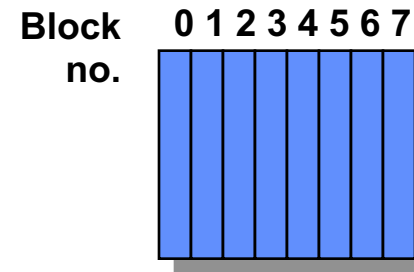

Which block should be replaced on a miss?

- Easy for Direct Mapped: Only one possibility
- Set Associative or Fully Associative:
 - Random
 - LRU (Least Recently Used)

Review: What happens on a write?

- **Write through:** The information is written to both the block in the cache and to the block in the lower-level memory
- **Write back:** The information is written only to the block in the cache
 - Modified cache block is written to main memory only when it is replaced
- Pros and Cons of each?
 - Write through:
 - » Pros: read misses cannot result in writes
 - » Cons: processor held up on writes
 - Write back:
 - » Pros: repeated writes not sent to DRAM
processor not held up on writes
 - » Cons: more complex
read miss may require writeback of dirty data

Summary (1/3)

- Page Tables
 - Memory divided into fixed-sized chunks of memory
 - Virtual page number from virtual address mapped through page table to physical page number
 - Offset of virtual address same as physical address
 - Large page table
- Multi-Level Tables
 - Virtual address mapped to series of tables
 - Permit sparse population of address space
- Inverted Page Table
 - Use of hash-table to hold translation entries
 - Size of page table \sim size of physical memory rather than size of virtual memory

Summary (2/3)

- The Principle of Locality:
 - Program likely to access a relatively small portion of the address space at any instant of time.
 - » **Temporal Locality:** Locality in Time
 - » **Spatial Locality:** Locality in Space
- Major Categories of Cache Misses:
 - **Compulsory Misses:** sad facts of life. Example: cold start misses.
 - **Conflict Misses:** increase cache size and/or associativity
 - **Capacity Misses:** increase cache size
 - **Coherence Misses:** Caused by external processors or I/O devices
- Cache Organizations:
 - Direct Mapped: single block per set
 - Set associative: more than one block per set
 - Fully associative: all entries equivalent

Summary (3/3)

- “Translation Lookaside Buffer” (TLB)
 - Small number of PTEs and optional process IDs (< 512)
 - Fully Associative (Since conflict misses expensive)
 - On TLB miss, page table must be traversed and if located PTE is invalid, cause Page Fault
 - On change in page table, TLB entries must be invalidated
 - TLB is logically in front of cache (need to overlap with cache access)