

Operating Systems (Honor Track)

IO: General I/O, Disk and SSD

Xin Jin

Spring 2026

Acknowledgments: Ion Stoica, Berkeley CS 162

Requirements of I/O

- So far, we have studied:
 - Abstractions: the APIs provided by the OS to applications running in a process
 - Synchronization/Scheduling: How to manage the CPU
 - Memory: How to manage the memory
- What about I/O?
 - Without I/O, computers are useless
 - But... thousands of devices, each slightly different
 - » How can we standardize the interfaces to these devices?
 - Devices unreliable: media failures and transmission errors
 - » How can we make them reliable?
 - Devices unpredictable and/or slow
 - » How can we manage them if we don't know what they will do or how they will perform?

Recall: OS Basics: I/O

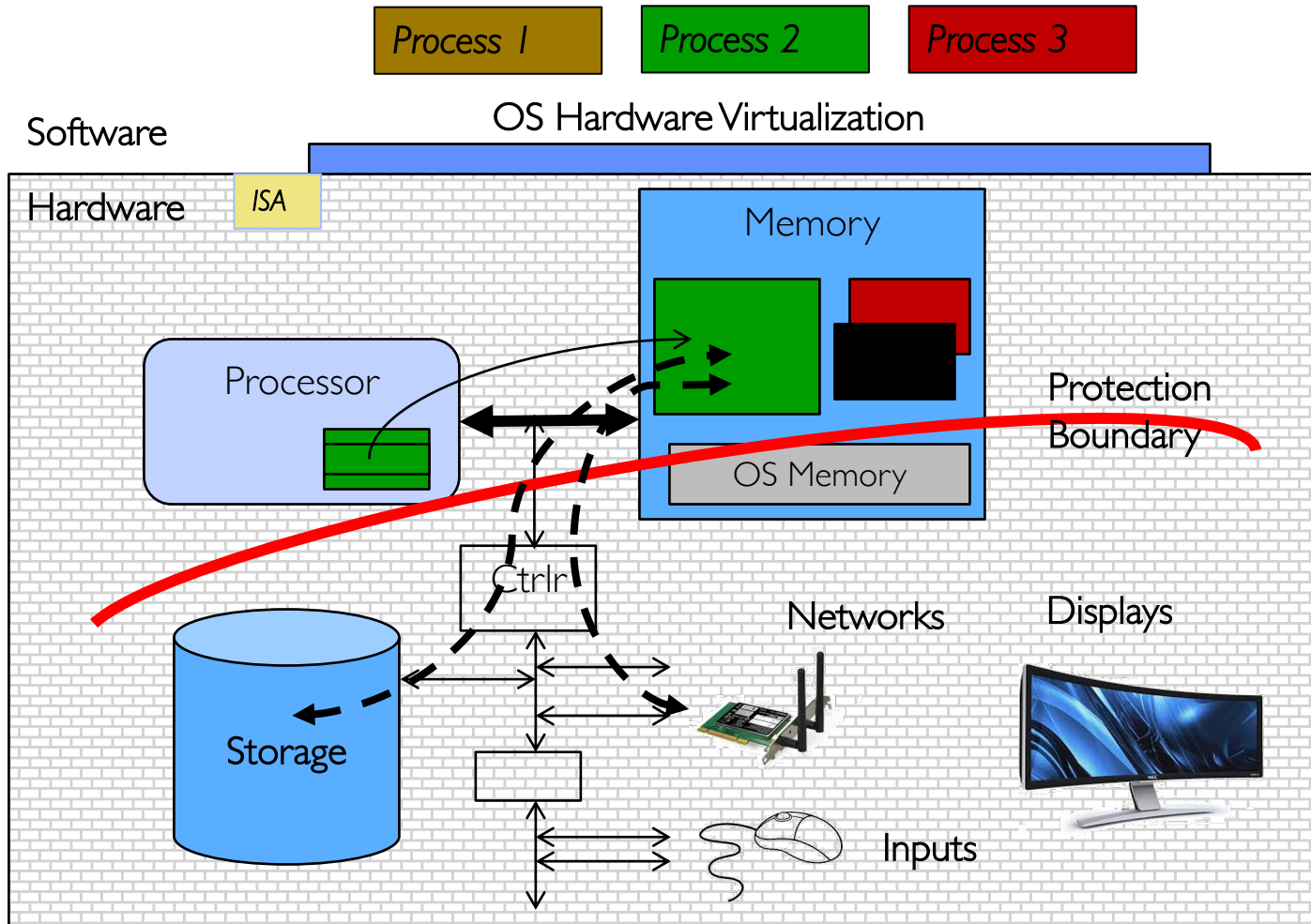

- OS provides common services in form of I/O

Example: Device Transfer Rates in Mb/s (Sun Enterprise 6000)

- Device rates vary over 12 orders of magnitude!!!
- System must be able to handle this wide range
 - Better not have high overhead/byte for fast devices
 - Better not waste time waiting for slow devices

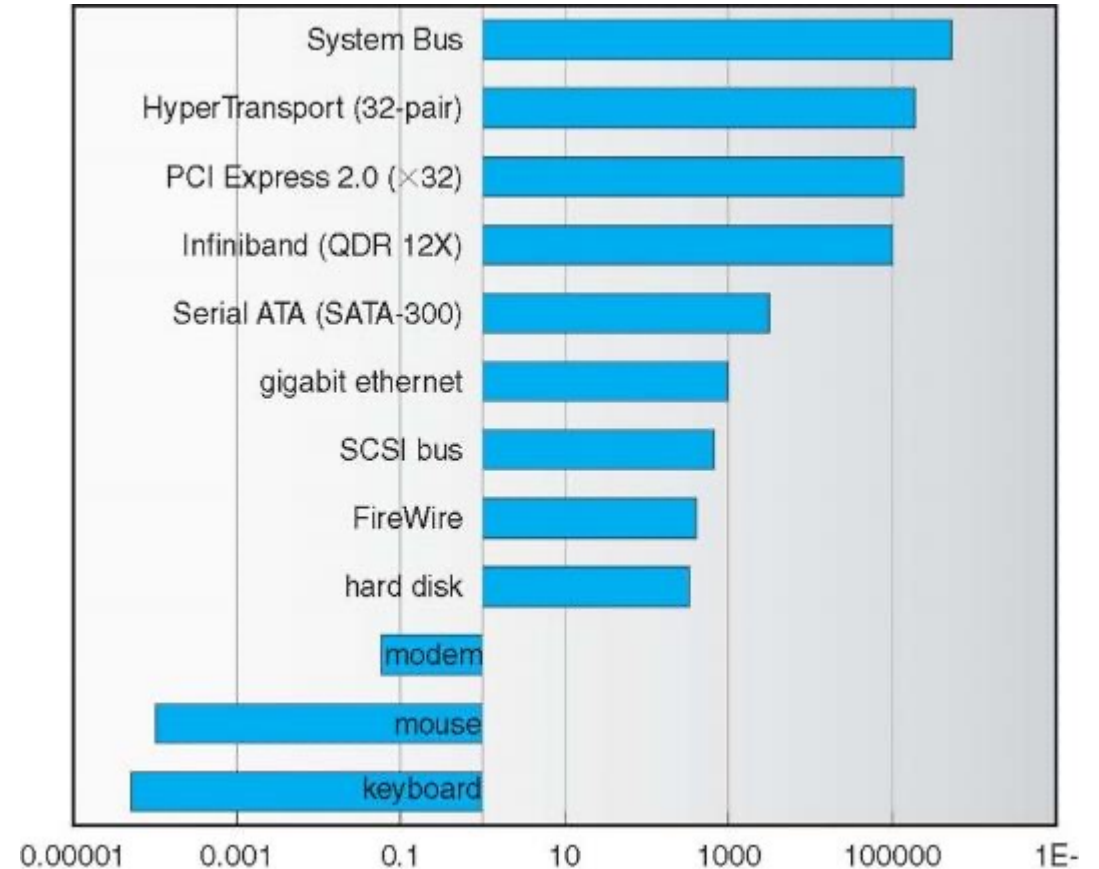

In a Picture

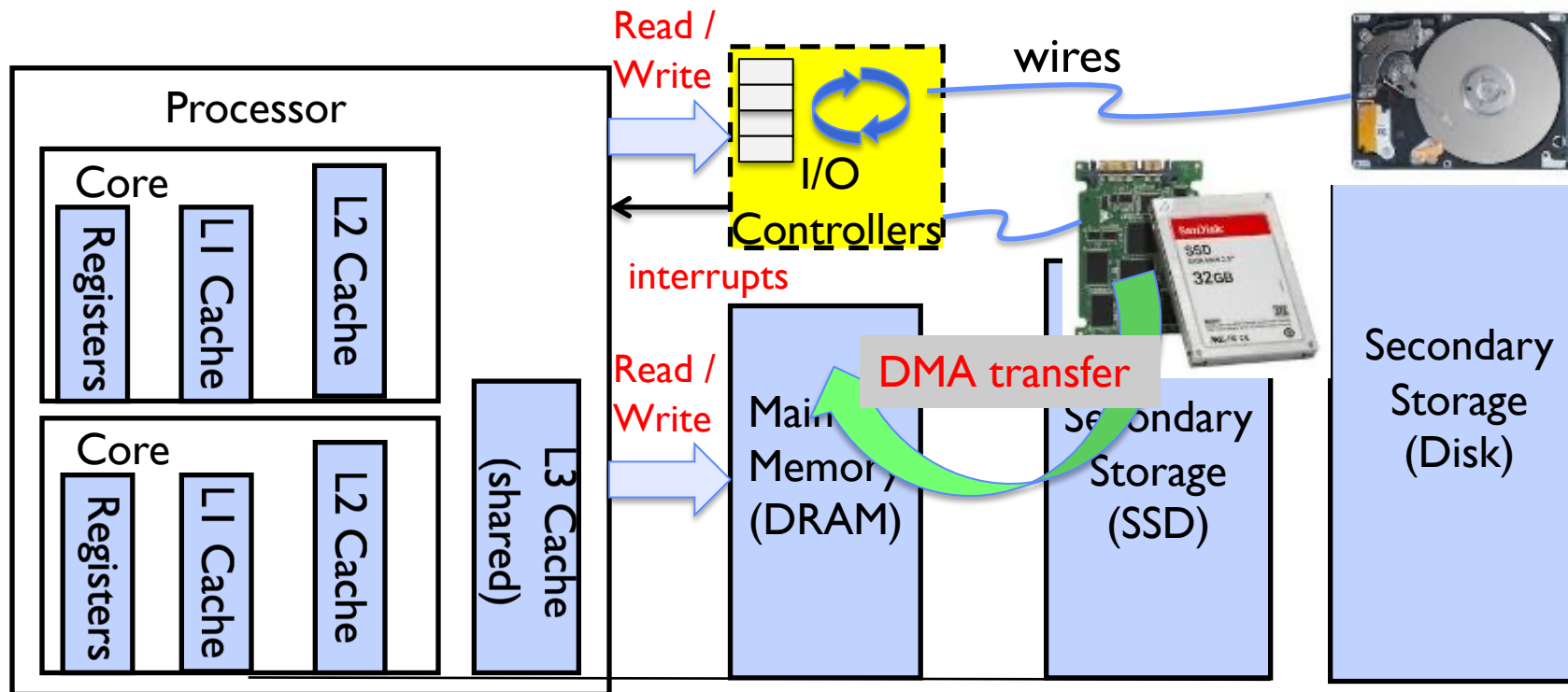

- I/O devices you recognize are supported by I/O Controllers
- Processors accesses them by reading and writing IO registers as if they were memory
 - Write commands and arguments, read status and results

Modern I/O Systems

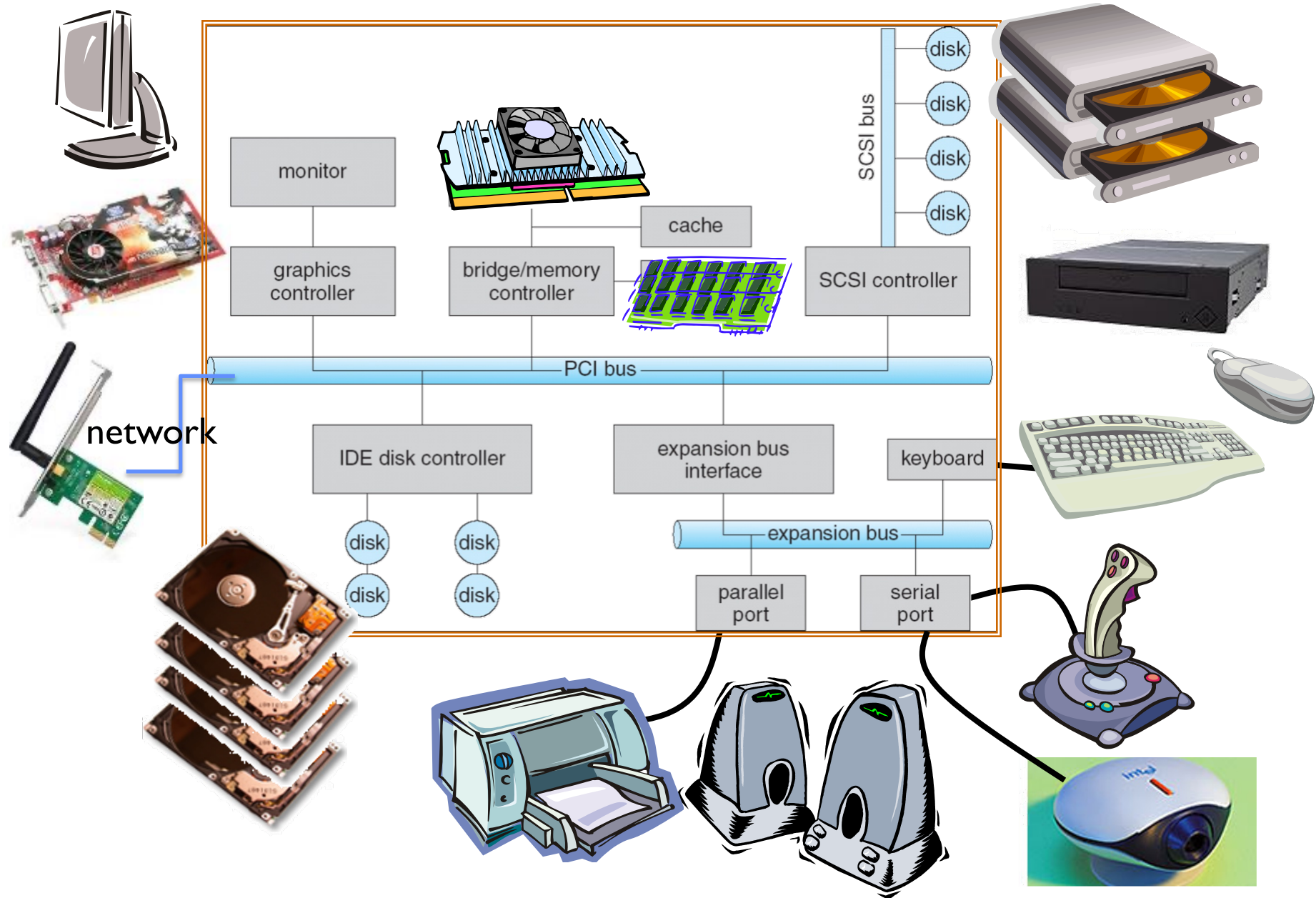

What's a bus?

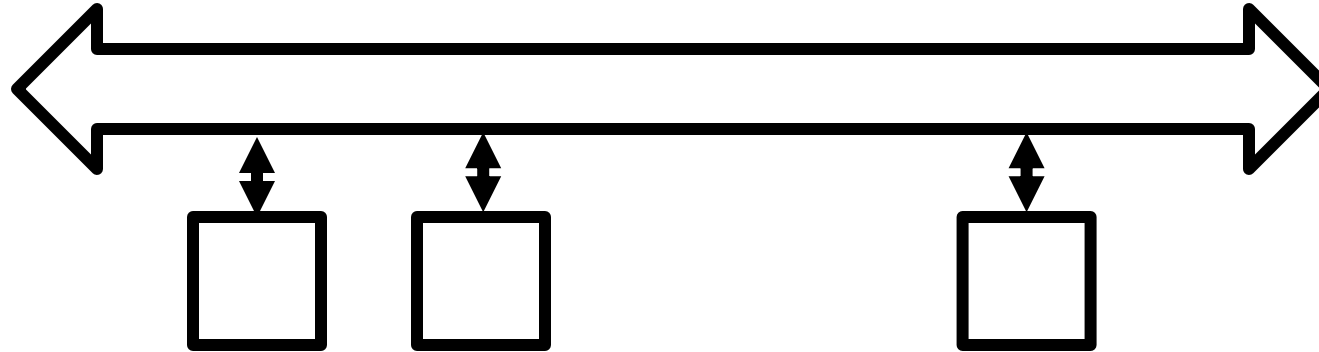

- Common set of wires for communication among hardware devices plus protocols for carrying out data transfer transactions
 - Operations: e.g., Read, Write
 - Control lines, Address lines, Data lines
 - Typically, multiple devices
- Protocol: initiator requests access, arbitration to grant, identification of recipient, handshake to convey address, length, data
- Very high BW close to processor (wide, fast, and inflexible), low BW with high flexibility out in I/O subsystem

Why a Bus?

- Buses let us connect n devices over a single set of wires, connections, and protocols
 - $O(n^2)$ relationships with 1 set of wires (!)
- Downside: Only one transaction at a time
 - The rest must wait
 - “Arbitration” aspect of bus protocol ensures the rest wait

PCI Bus Evolution

- PCI (Peripheral Component Interconnect) started life out as a bus
- But a parallel bus has many limitations
 - Multiplexing address/data for many requests
 - Slowest devices must be able to tell what's happening (e.g., for arbitration)

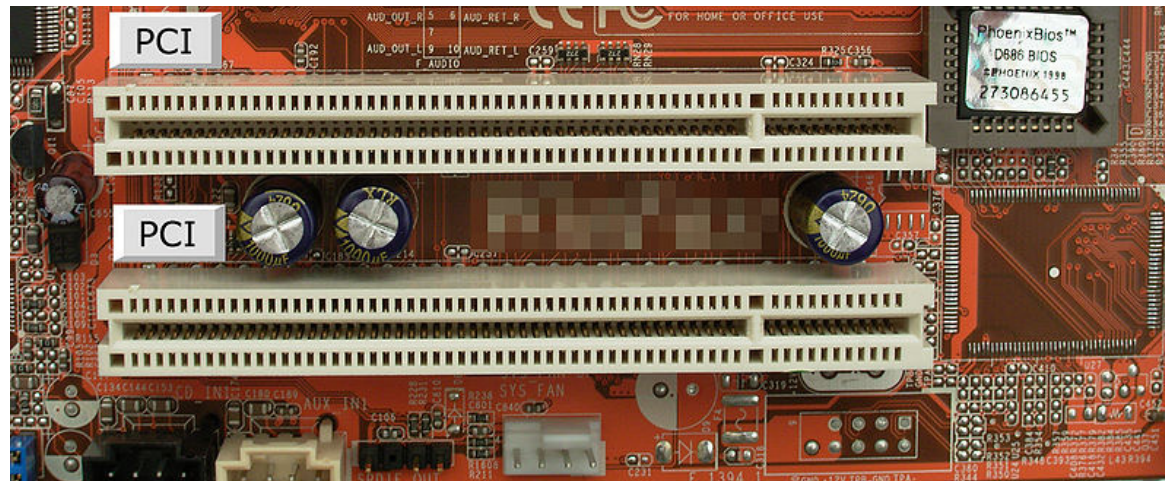

PCI Express “Bus”

- No longer a parallel bus
- Really a **collection of fast serial channels** or “lanes”
- Devices can use as many as they need to achieve a desired bandwidth
- Slow devices don’t have to share with fast ones
 - Space multiplexing vs. time multiplexing
- One of the successes of device abstraction in Linux was the ability to migrate from PCI to PCI Express
 - The physical interconnect changed completely, but the old API still worked

Example: PCI Architecture

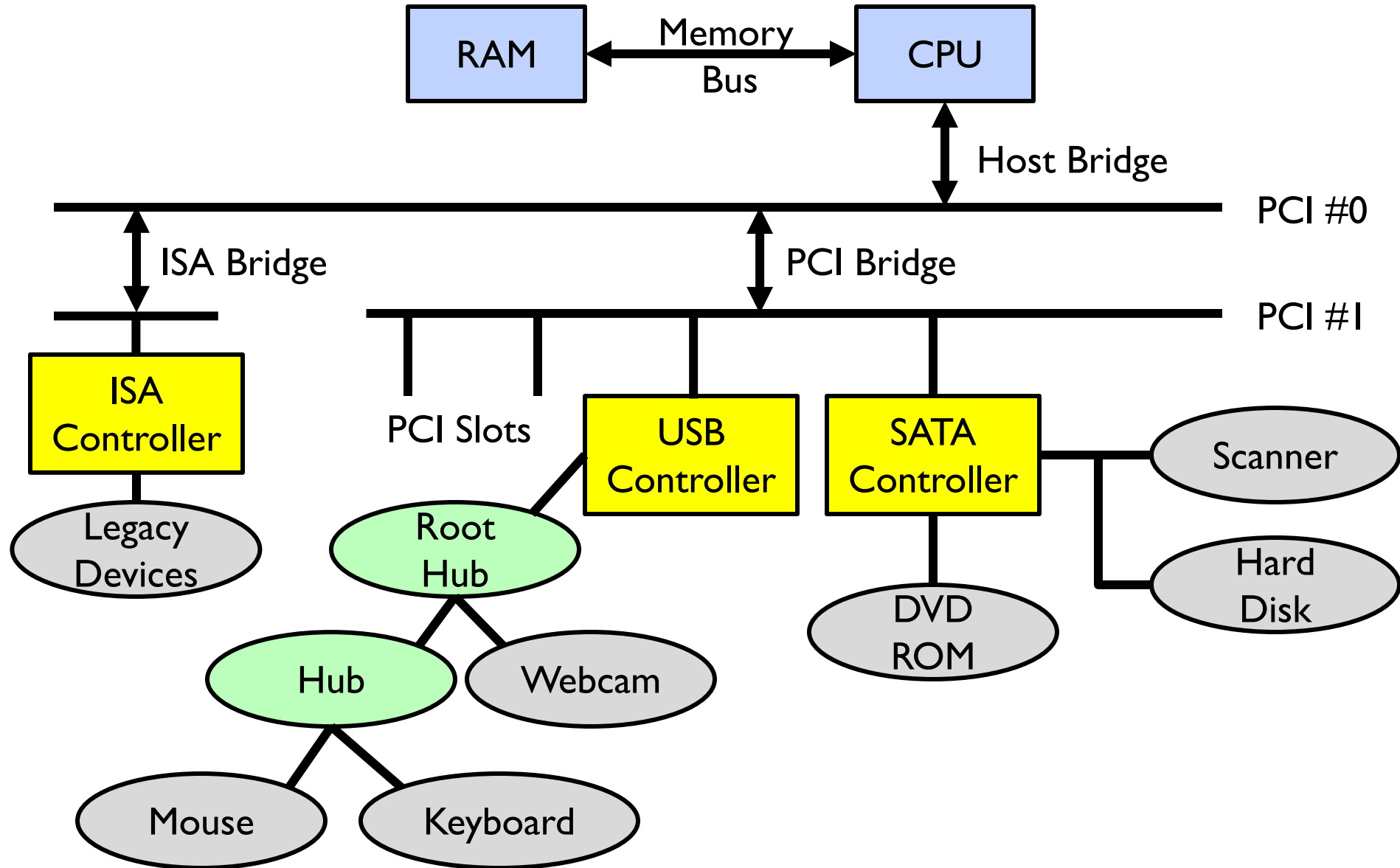

How does the Processor Talk to the Device?

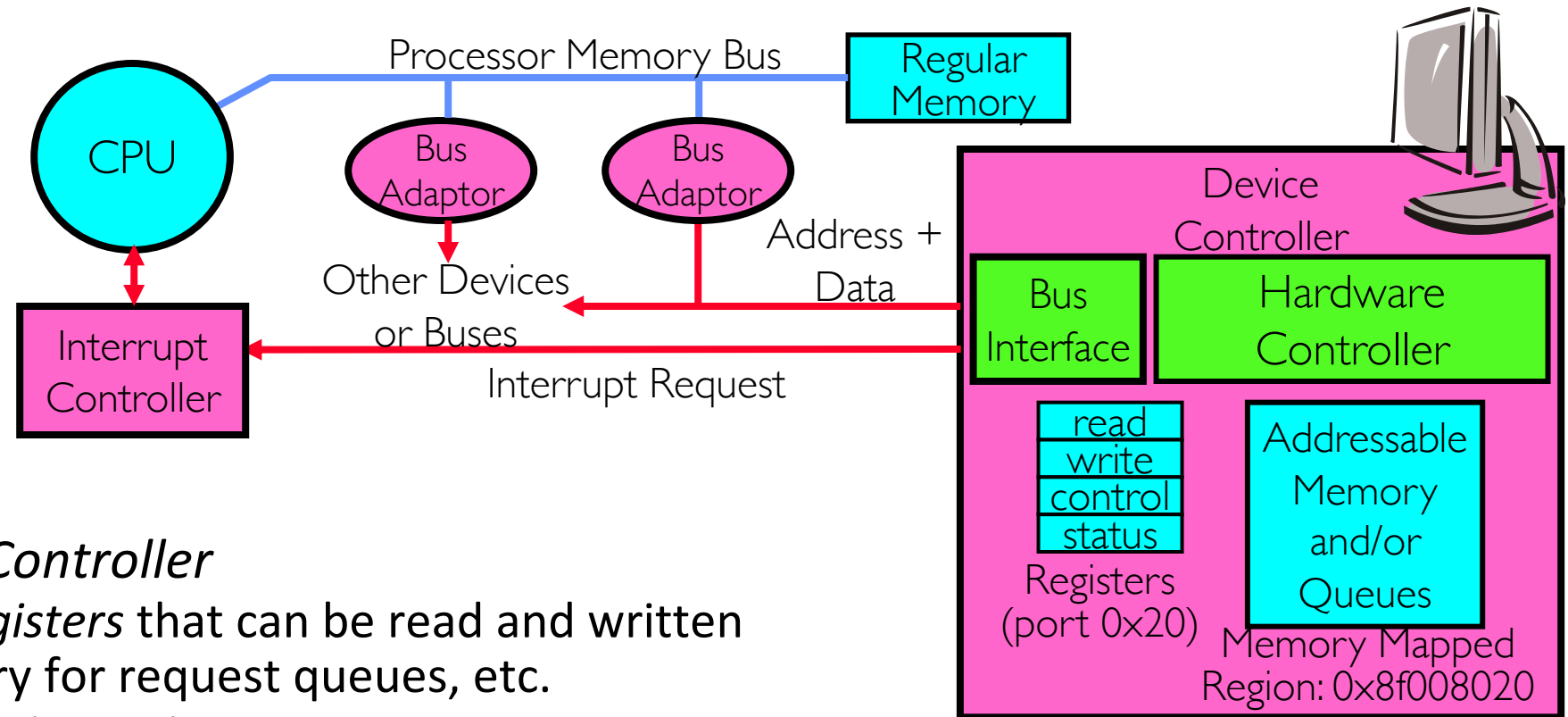

- CPU interacts with a *Controller*
 - Contains a set of *registers* that can be read and written
 - May contain memory for request queues, etc.
- Processor accesses registers in two ways:
 - **Port-Mapped I/O**: in/out instructions
 - » Example from the Intel architecture: `out 0x21, AL`
 - **Memory-mapped I/O**: load/store instructions
 - » Registers/memory appear in physical address space
 - » I/O accomplished with load and store instructions

Example: Memory-Mapped Display Controller

- Memory-Mapped:
 - Hardware maps control registers and display memory into physical address space
 - » Addresses set by HW jumpers or at boot time
 - Simply writing to display memory (also called the “frame buffer”)
 - » Addr: 0x8000F000 — 0x8000FFFF
 - Writing graphics description to cmd queue
 - » Say enter a set of triangles describing some scene
 - » Addr: 0x80010000 — 0x8001FFFF
 - Writing to the command register may cause on-board graphics hardware to do something
 - » Say render the above scene
 - » Addr: 0x0007F004
- Can protect with address translation

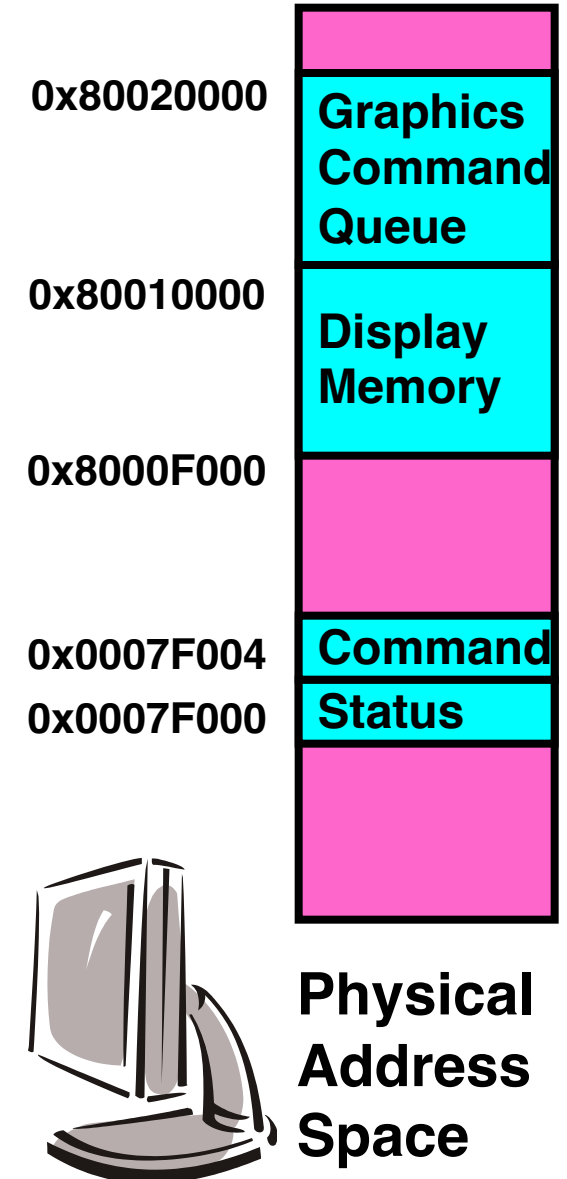

There's more than just a CPU in there!



Chip-scale Features of 2015 x86 (Sky Lake)

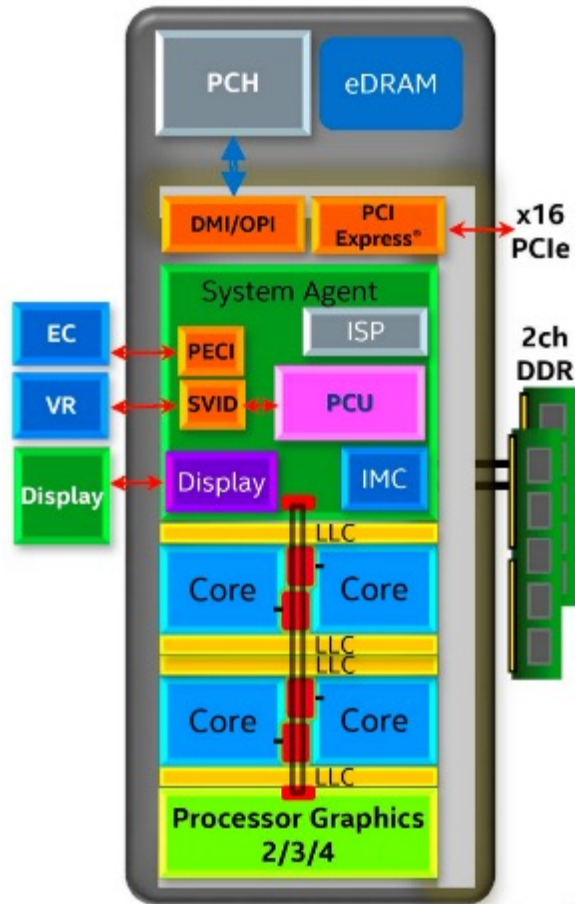

- Significant pieces:
 - Four OOO cores with deeper buffers
 - » Intel MPX (Memory Protection Extensions)
 - » Intel SGX (Software Guard Extensions)
 - » Issue up to 6 μ -ops/cycle
 - GPU, System Agent (Mem, Fast I/O)
 - Large shared L3 cache with on-chip ring bus
 - » 2 MB/core instead of 1.5 MB/core
 - » High-BW access to L3 Cache
- Integrated I/O
 - Integrated memory controller (IMC)
 - » Two independent channels of DRAM
 - High-speed PCI-Express (for Graphics cards)
 - Direct Media Interface (DMI) Connection to PCH (Platform Control Hub)

Sky Lake I/O: PCH

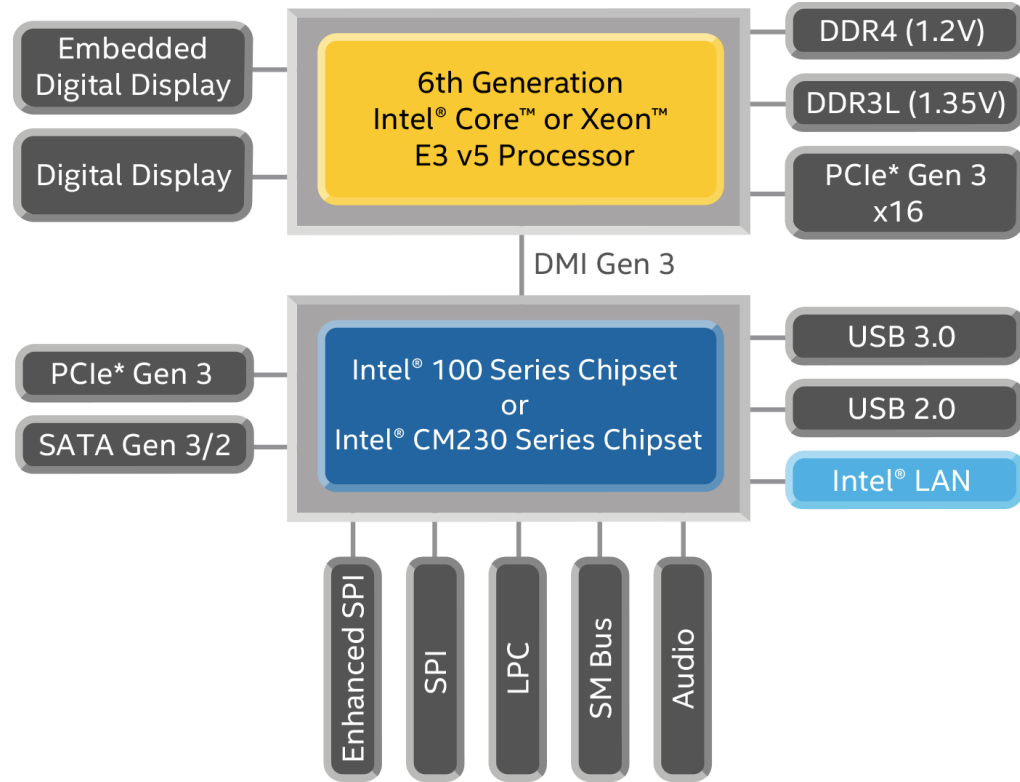

Sky Lake System Configuration

- **Platform Controller Hub**
 - Connected to processor with proprietary bus
 - » Direct Media Interface (DMI)
- Types of I/O on PCH:
 - USB, Ethernet
 - Thunderbolt 3
 - Audio, BIOS support
 - More PCI Express (lower speed than on Processor)
 - SATA (for Disks)

Operational Parameters for I/O

- Data granularity: Byte vs. Block
 - Some devices provide single byte at a time (e.g., keyboard)
 - Others provide whole blocks (e.g., disks, networks, etc.)
- Access pattern: Sequential vs. Random
 - Some devices must be accessed sequentially (e.g., tape)
 - Others can be accessed “randomly” (e.g., disk, cd, etc.)
 - » Fixed overhead to start transfers
 - Some devices require continual monitoring (polling)
 - Others generate interrupts when they need service (e.g., keyboard, network card)
- Transfer Mechanism: Programmed IO and DMA (Directed Memory Access)

Transferring Data To/From Controller

- **Programmed I/O:**
 - Each byte transferred via processor in/out or load/store
 - Pro: Simple hardware, easy to program
 - Con: Consumes processor cycles proportional to data size

- **Direct Memory Access:**
 - Give controller access to memory bus
 - Ask it to transfer data blocks to/from memory directly

- Sample interaction with DMA controller:

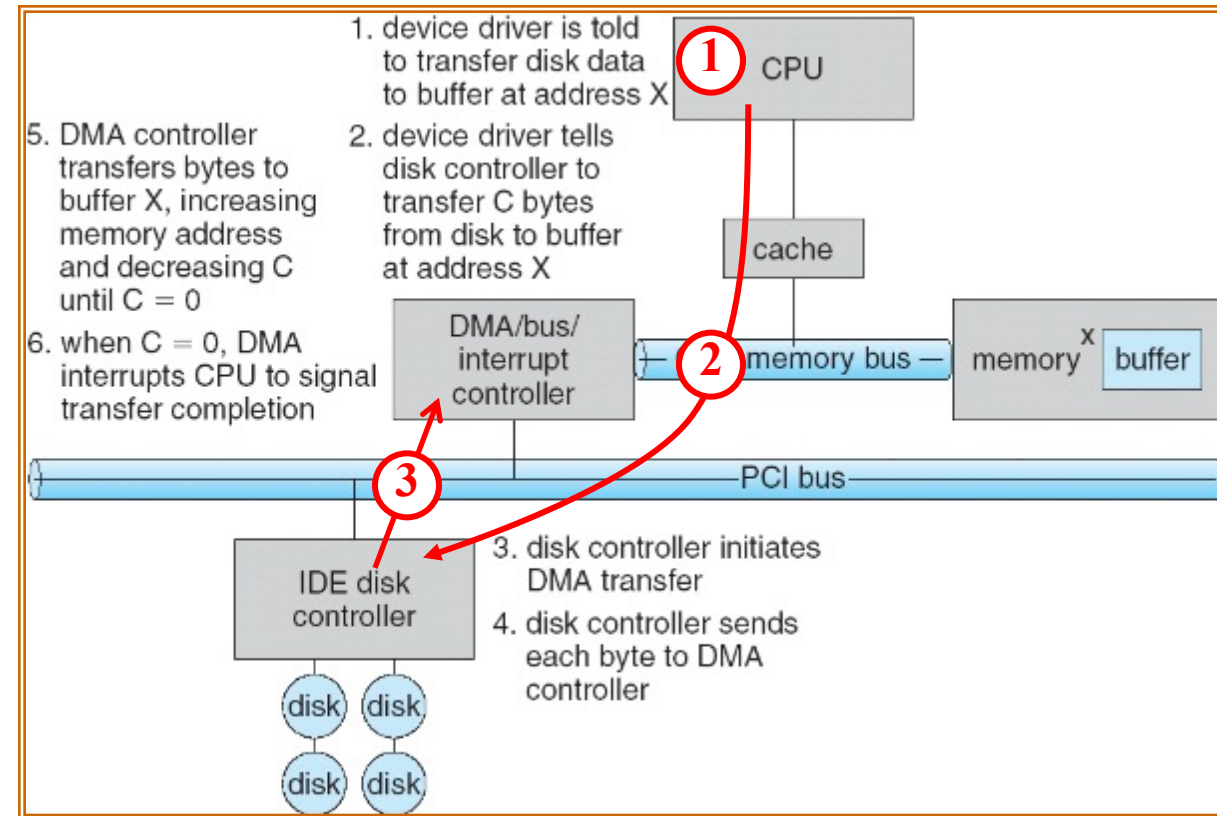

Transferring Data To/From Controller

- **Programmed I/O:**
 - Each byte transferred via processor in/out or load/store
 - Pro: Simple hardware, easy to program
 - Con: Consumes processor cycles proportional to data size

- **Direct Memory Access:**
 - Give controller access to memory bus
 - Ask it to transfer data blocks to/from memory directly

- Sample interaction with DMA controller:

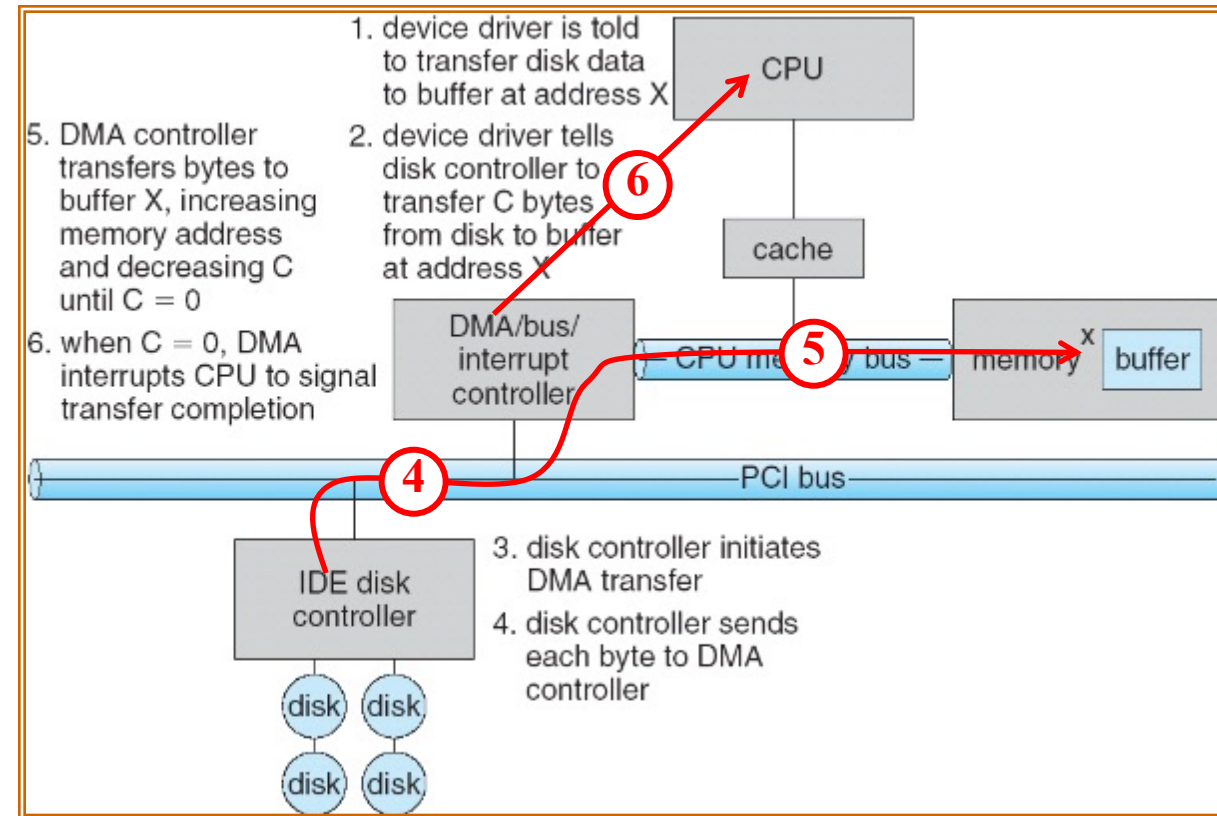

I/O Device Notifying the OS

- The OS needs to know when:
 - The I/O device has completed an operation
 - The I/O operation has encountered an error
- **I/O Interrupt:**
 - Device generates an interrupt whenever it needs service
 - Pro: handles unpredictable events well
 - Con: interrupts relatively high overhead
- **Polling:**
 - OS periodically checks a device-specific status register
 - » I/O device puts completion information in status register
 - Pro: low overhead
 - Con: may waste many cycles on polling if infrequent or unpredictable I/O operations
- **Actual devices combine both polling and interrupts**
 - For instance – High-bandwidth network adapter:
 - » Interrupt for first incoming packet
 - » Poll for following packets until hardware queues are empty

Kernel Device Structure

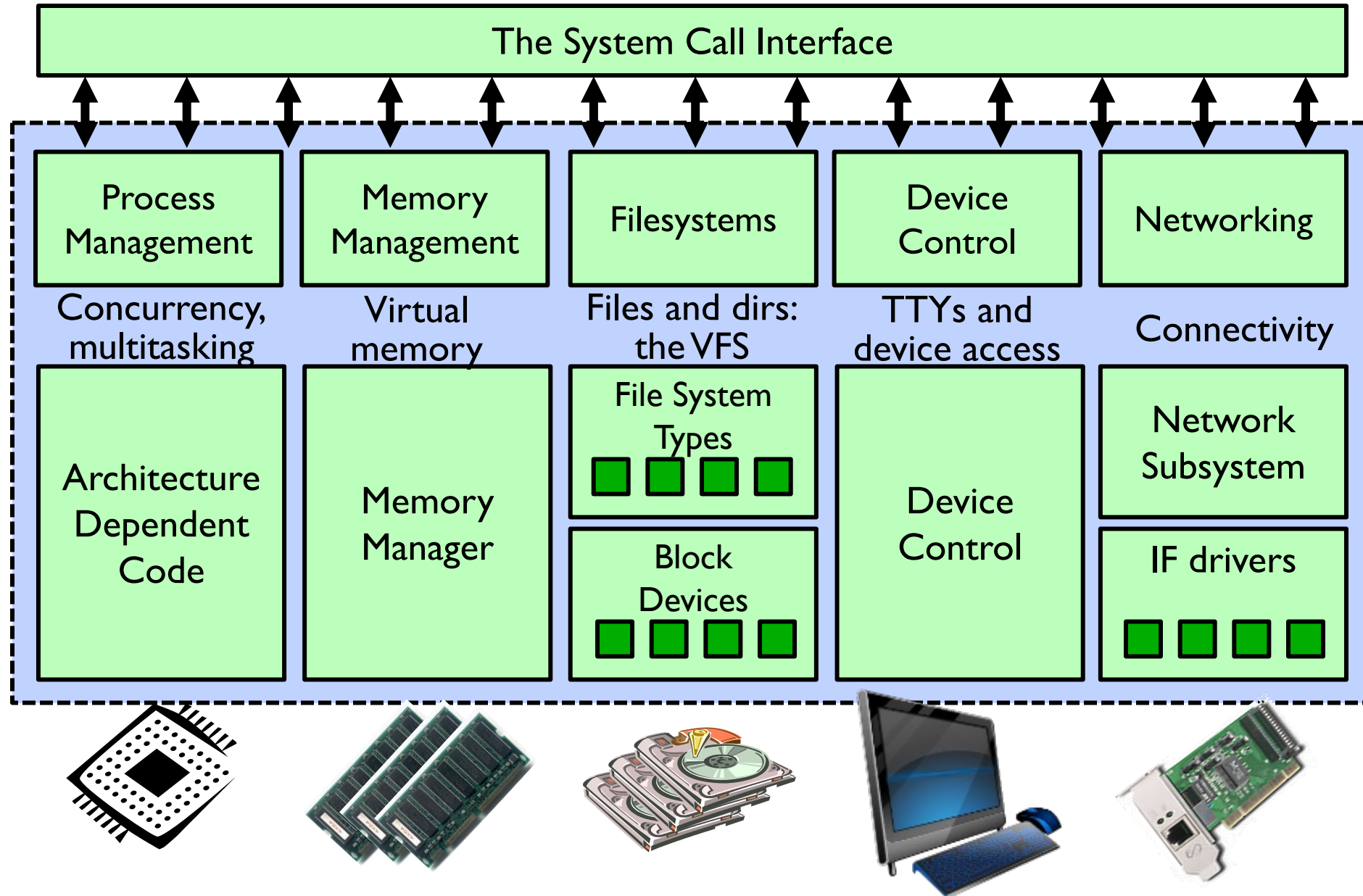

Device Drivers

- **Device Driver:** Device-specific code in the kernel that interacts directly with the device hardware
 - Supports a standard, internal interface
 - Same kernel I/O system can interact easily with different device drivers
 - Special device-specific configuration supported with the `ioctl()` system call
- Device Drivers typically divided into two pieces:
 - Top half: accessed in call path from system calls
 - » implements a set of **standard, cross-device calls** like `open()`, `close()`, `read()`, `write()`, `ioctl()`
 - » This is the kernel's interface to the device driver
 - » Top half will *start* I/O to device, may put thread to sleep until finished
 - Bottom half: run as interrupt routine
 - » Gets input or transfers next block of output
 - » May wake sleeping threads if I/O now complete

Life Cycle of An I/O Request

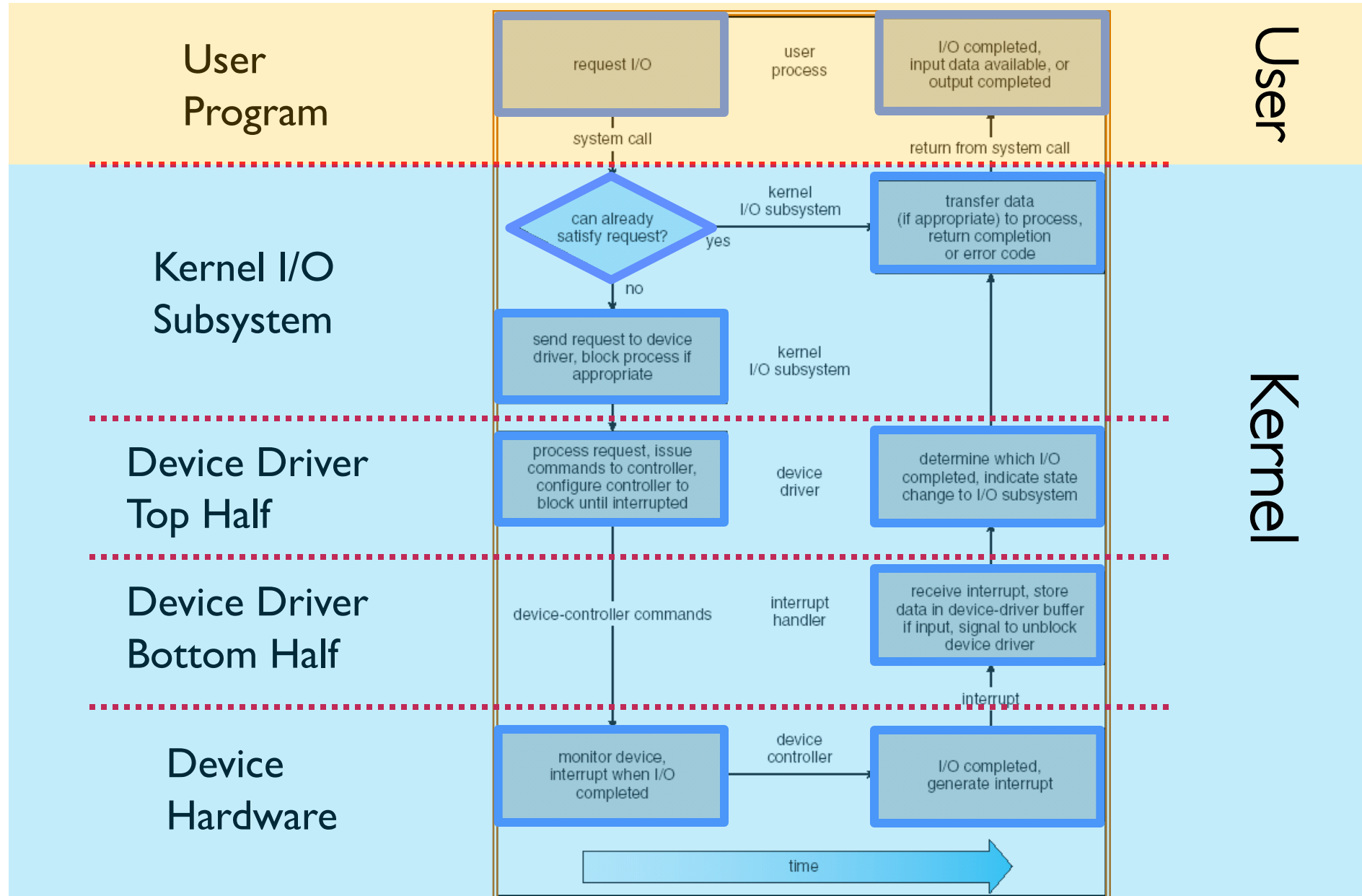

The Goal of the I/O Subsystem

- Provide Uniform Interfaces, Despite Wide Range of Different Devices

- This code works on many different devices:

```
FILE fd = fopen("/dev/something", "rw");
for (int i = 0; i < 10; i++) {
    fprintf(fd, "Count %d\n", i);
}
close(fd);
```

- Why? Because code that controls devices (“device driver”) implements standard interface

- We will try to get a flavor for what is involved in actually controlling devices in rest of lecture

- Can only scratch surface!

Want Standard Interfaces to Devices

- **Block Devices:** *e.g.* disk drives, tape drives, DVD-ROM
 - Access blocks of data
 - Commands include `open()`, `read()`, `write()`, `seek()`
 - Raw I/O or file-system access
 - Memory-mapped file access possible
- **Character Devices:** *e.g.* keyboards, mice, serial ports, some USB devices
 - Single characters at a time
 - Commands include `get()`, `put()`
 - Libraries layered on top allow line editing
- **Network Devices:** *e.g.* Ethernet, Wireless, Bluetooth
 - Different enough from block/character to have own interface
 - Unix and Windows include **socket** interface
 - » Separates network protocol from network operation
 - » Includes `select()` functionality
 - Usage: pipes, FIFOs, streams, queues, mailboxes

How Does User Deal with Timing?

- **Blocking Interface: “Wait”**
 - When request data (e.g. `read()` system call), put process to sleep until data is ready
 - When write data (e.g. `write()` system call), put process to sleep until device is ready for data
- **Non-blocking Interface: “Don’t Wait”**
 - Returns quickly from read or write request with count of bytes successfully transferred
 - Read may return nothing, write may write nothing
- **Asynchronous Interface: “Tell Me Later”**
 - When request data, take pointer to user’s buffer, return immediately; later kernel fills buffer and notifies user
 - When send data, take pointer to user’s buffer, return immediately; later kernel takes data and notifies user

Storage Devices

- Magnetic disks
 - Storage that rarely becomes corrupted
 - Large capacity at low cost
 - Block level random access
 - Slow performance for random access
 - Better performance for sequential access
- Flash memory
 - Storage that rarely becomes corrupted
 - Capacity at intermediate cost (5-20x disk, the gap is decreasing)
 - Block level random access
 - Good performance for reads; worse for random writes
 - Erasure requirement in large blocks
 - Ability to store data degrades with the number of writes

Hard Disk Drives (HDDs)

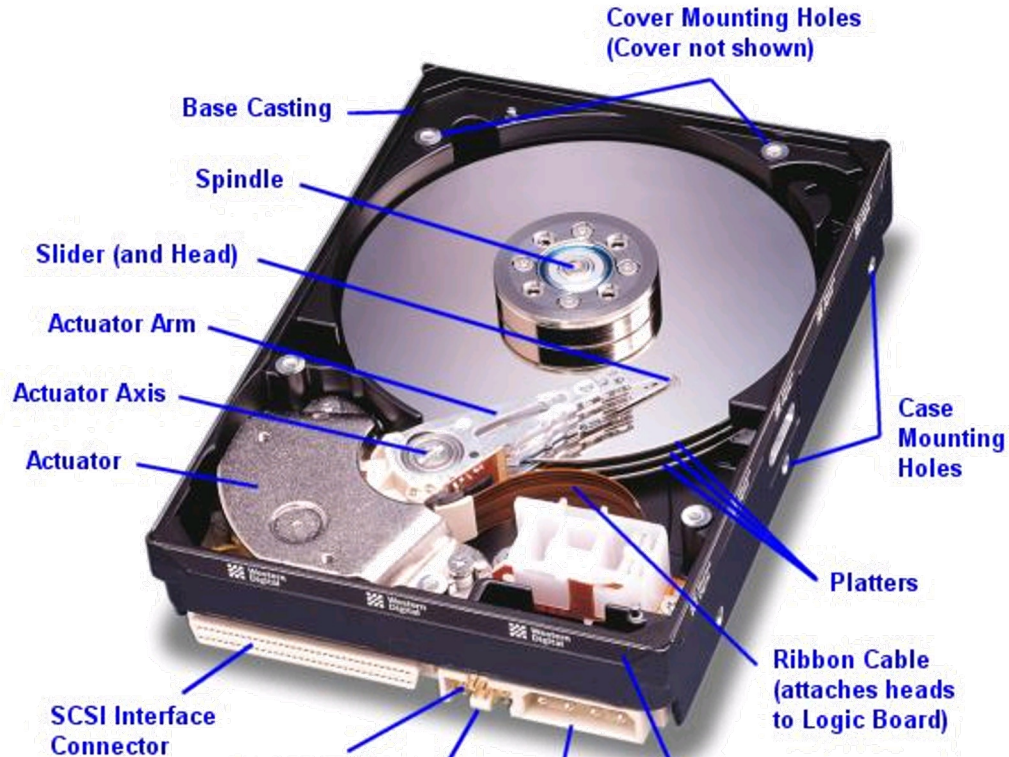

Western Digital Drive

<http://www.storagereview.com/guide/>



IBM/Hitachi Microdrive



Read/Write Head Side View

IBM Personal Computer/AT (1986)

30 MB hard disk - \$500

30-40ms seek time

0.7-1 MB/s (est.)

The Amazing Magnetic Disk

- Unit of Transfer: **Sector**
 - Ring of sectors form a **track**
 - Stack of tracks form a **cylinder**
 - Heads position on **cylinders**

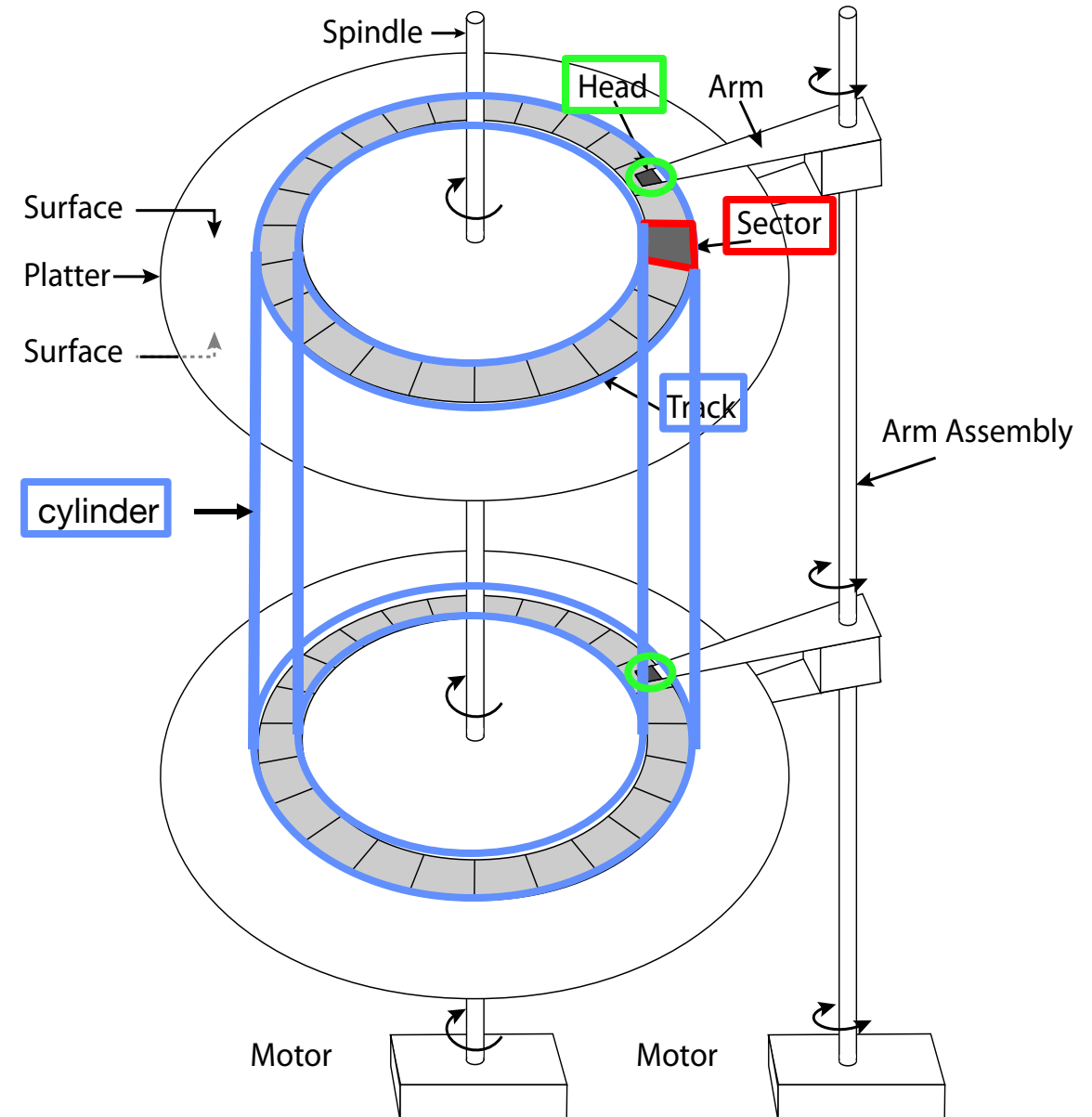

The Amazing Magnetic Disk

- Unit of Transfer: **Sector**
 - Ring of sectors form a **track**
 - Stack of tracks form a **cylinder**
 - Heads position on **cylinders**
- Disk Tracks $\sim 1\mu\text{m}$ (micron) wide
 - Wavelength of light is $\sim 0.5\mu\text{m}$
 - Resolution of human eye: $50\mu\text{m}$
 - 100K tracks on a typical 2.5" disk
- Separated by unused guard regions
 - Reduces likelihood neighboring tracks are corrupted during writes (still a small non-zero chance)

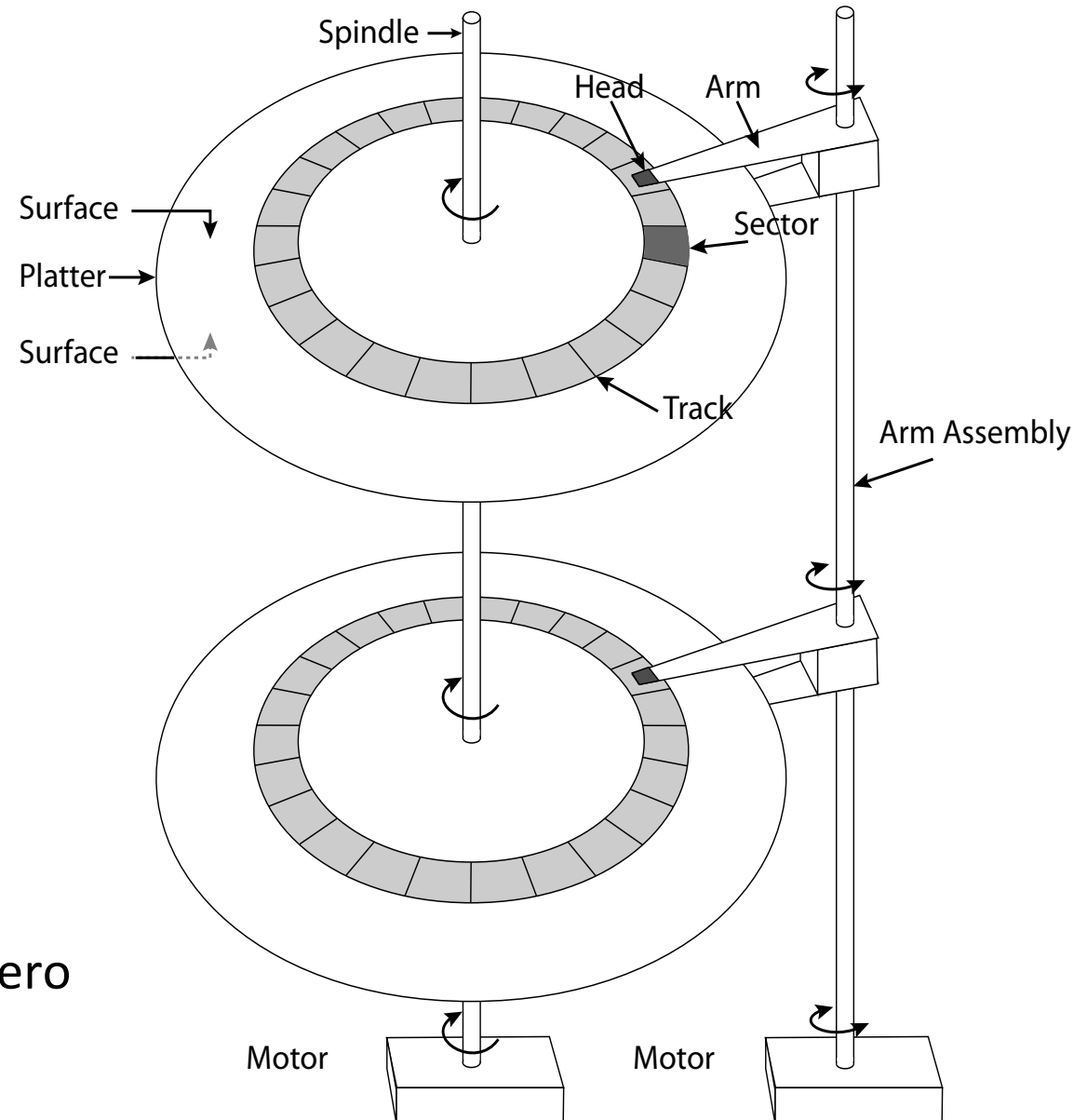

The Amazing Magnetic Disk

- Track length varies across disk
 - Outside: More sectors per track, higher bandwidth
 - Disk is organized into regions of tracks with same # of sectors/track
 - » Most of the disk area in the outer regions of the disk
 - Only outer half of radius is used
- Disks so big that some companies (like Google) reportedly only use part of disk for active data
 - Rest is archival data

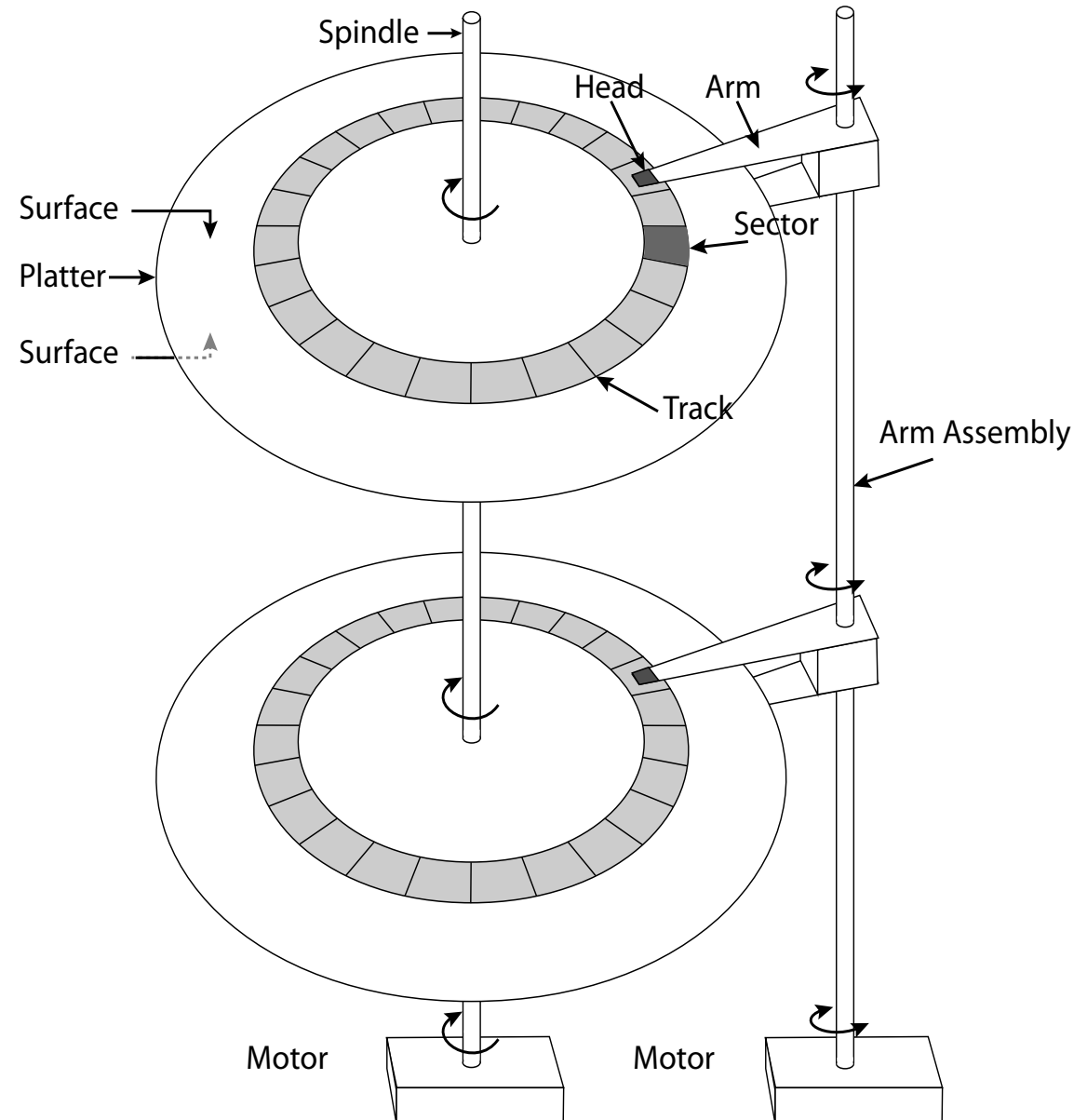

Shingled Magnetic Recording (SMR)

- Overlapping tracks yields greater density, capacity
- Restrictions on writing, complex DSP (Digital Signal Processing) for reading

Conventional Writes

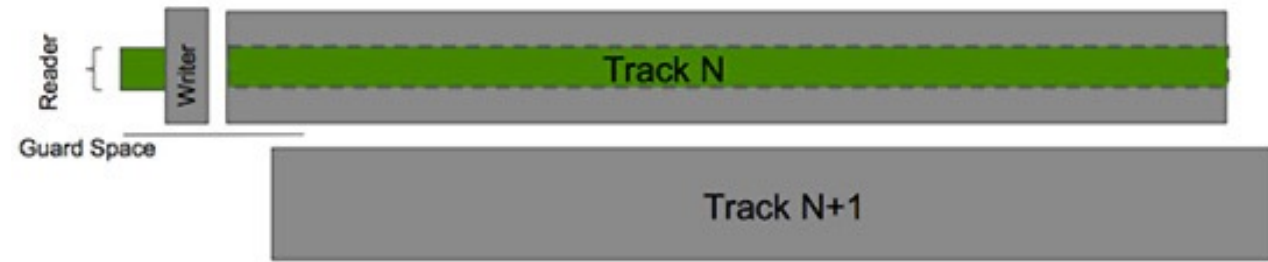

SMR Writes

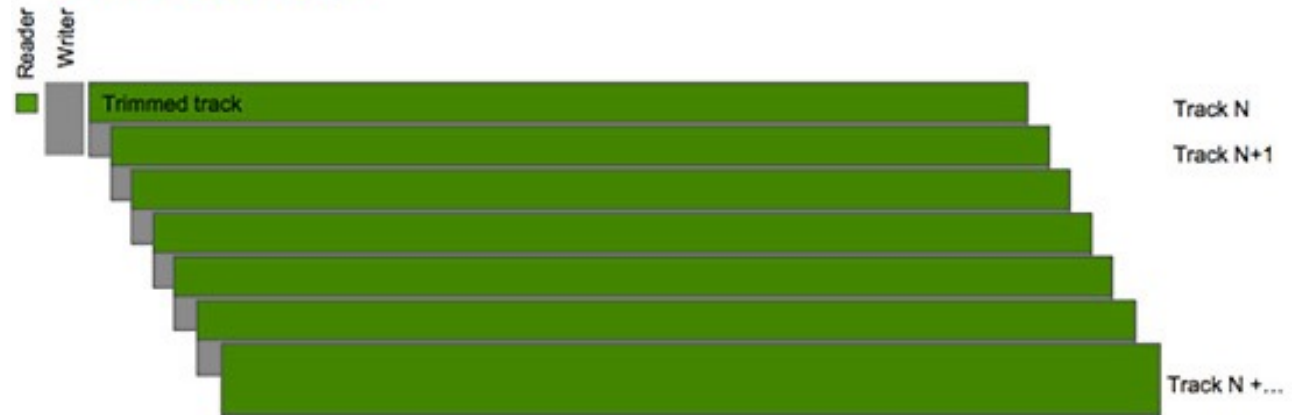

Magnetic Disks

- **Cylinders:** all the tracks under the head at a given point on all surfaces
- Read/write data is a three-stage process:
 - **Seek time:** position the head/arm over the proper track
 - **Rotational latency:** wait for desired sector to rotate under r/w head
 - **Transfer time:** transfer a block of bits (sector) under r/w head

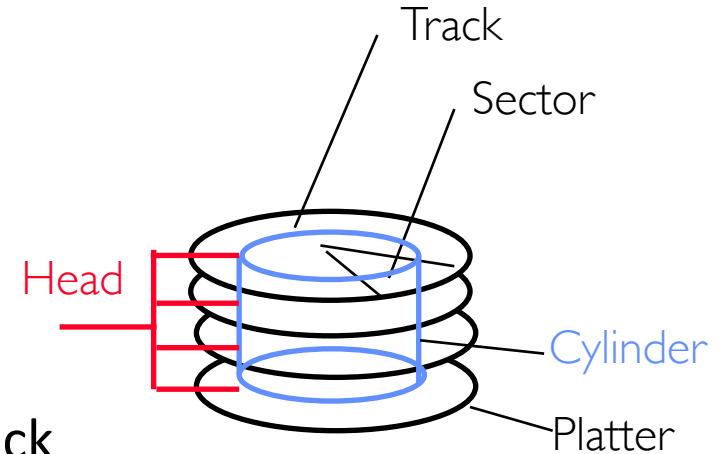

$$\text{Disk Latency} = \text{Queueing Time} + \text{Controller time} + \text{Seek Time} + \text{Rotation Time} + \text{Xfer Time}$$

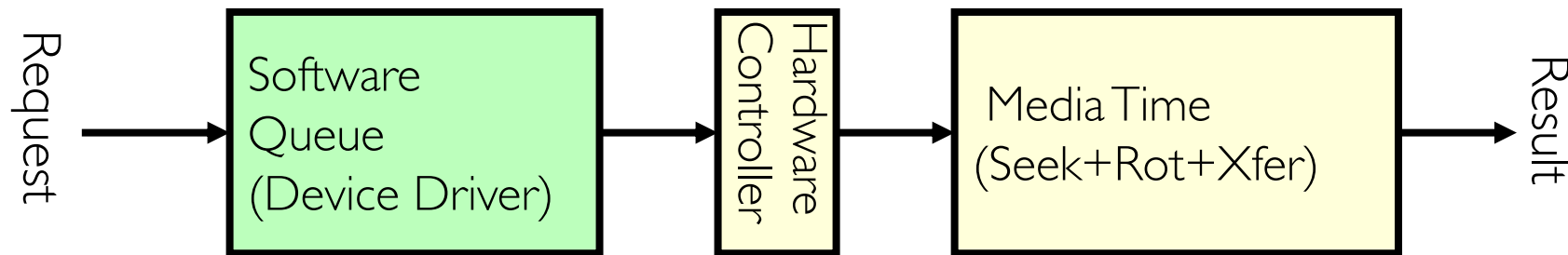

Typical Numbers for Magnetic Disk

Parameter	Info/Range
Space/Density	Space: 14TB (Seagate), 8 platters, in 3½ inch form factor! Areal Density: ≥ 1 Terabit/square inch!
Average Seek Time	Typically, 4-6 milliseconds
Average Rotational Latency	Most laptop/desktop disks rotate at 3600-7200 RPM (16-8 ms/rotation). Server disks up to 15,000 RPM. Average latency is halfway around disk so 4-8 milliseconds
Controller Time	Depends on controller hardware
Transfer Time	Typically, 50 to 250 MB/s. Depends on: <ul style="list-style-type: none">• Transfer size (usually a sector): 512B – 1KB per sector• Rotation speed: 3600 RPM to 15000 RPM• Recording density: bits per inch on a track• Diameter: ranges from 1 in to 5.25 in
Cost	Used to drop by a factor of two every 1.5 years (or faster), now slowing down

Disk Performance Example

- Assumptions:
 - Ignoring queuing and controller times for now
 - Avg seek time of 5ms
 - 7200RPM \Rightarrow Time for rotation: $60000 \text{ (ms/min)} / 7200 \text{ (rev/min)} \approx 8\text{ms}$
 - Transfer rate of 50MByte/s, block size of 4Kbyte \Rightarrow
 $4096 \text{ bytes} / (50 \times 10^6 \text{ (bytes/s)}) = 81.92 \times 10^{-6} \text{ sec} \cong 0.082 \text{ ms}$ for 1 block
- Read block from random place on disk:
 - Seek (5ms) + Rot. Delay (4ms) + Transfer (0.082ms) = 9.082ms
 - Approx 9ms to fetch/put data: $4096 \text{ bytes} / 9.082 \times 10^{-3} \text{ s} \cong 451\text{KB/s}$
- Read block from random place in same cylinder:
 - Rot. Delay (4ms) + Transfer (0.082ms) = 4.082ms
 - Approx 4ms to fetch/put data: $4096 \text{ bytes} / 4.082 \times 10^{-3} \text{ s} \cong 1.03\text{MB/s}$
- Read next block on same track:
 - Transfer (0.082ms): $4096 \text{ bytes} / 0.082 \times 10^{-3} \text{ s} \cong 50\text{MB/sec}$
- **Key to using disk effectively (especially for file systems) is to minimize seek and rotational delays**

Lots of Intelligence in the Controller

- Sectors contain sophisticated error correcting codes
 - Hide corruptions due to neighboring track writes
- Sector sparing
 - Remap bad sectors transparently to spare sectors on the same surface
- Slip sparing
 - Remap all sectors (when there is a bad sector) to preserve sequential behavior
- Track skewing
 - Sector numbers offset from one track to the next, to allow for disk head movement for sequential ops

Track Skewing

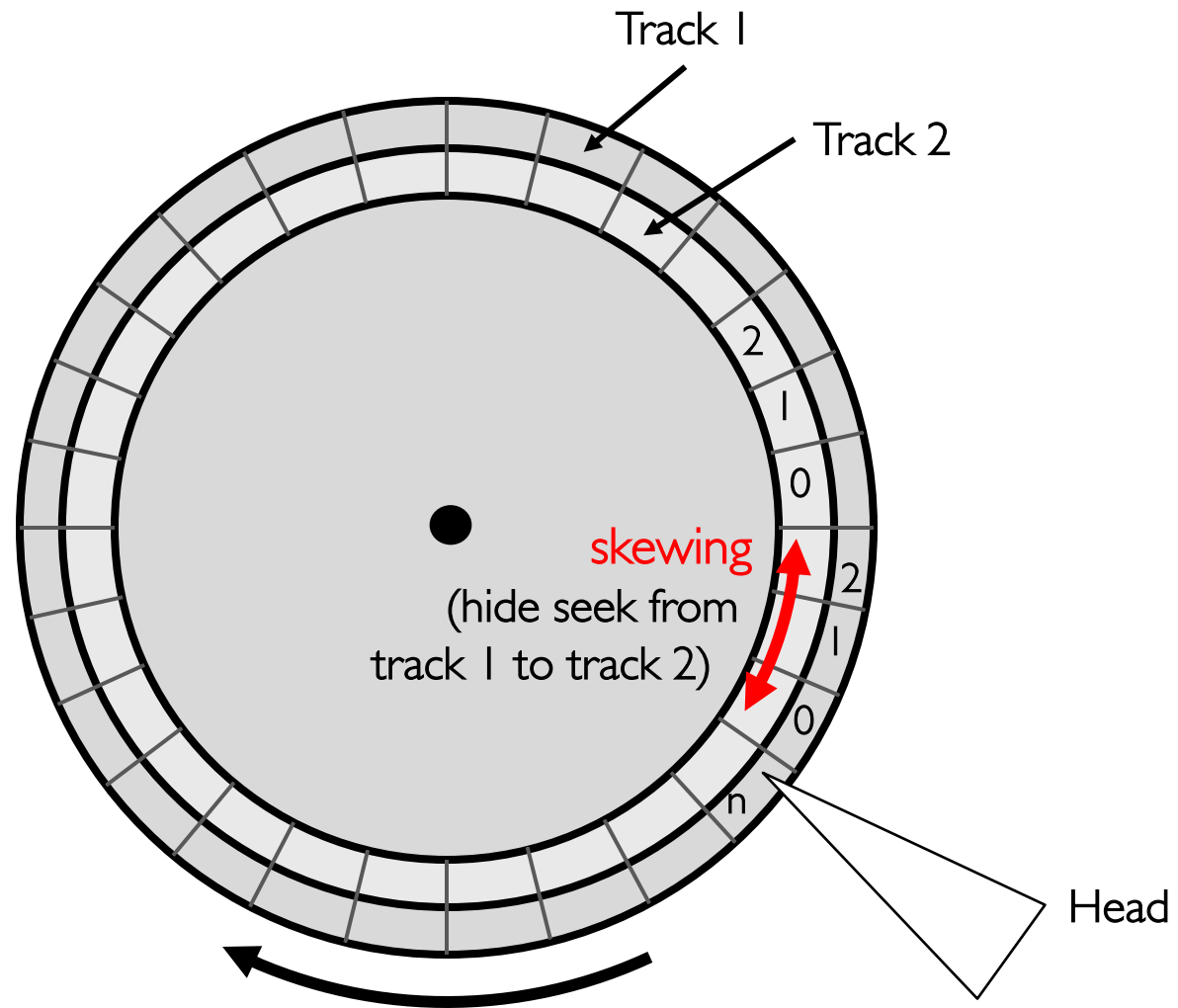

Example of Current HDDs

- Seagate Exos X18 (2020)
 - 18 TB hard disk
 - » 9 platters, 18 heads
 - » Helium filled: reduce friction and power
 - 4.16 ms average seek time
 - 4096 byte physical sectors
 - 7200 RPMs
 - Dual 6 Gbps SATA /12Gbps SAS interface
 - » 270MB/s MAX transfer rate
 - » Cache size: 256MB
 - Price: \$ 562 (~ \$0.03/GB)
- IBM Personal Computer/AT (1986)
 - 30 MB hard disk
 - 30-40 ms seek time
 - 0.7-1 MB/s (est.)
 - Price: \$500 (\$17K/GB)

600K x

300 x

567K x

10 x

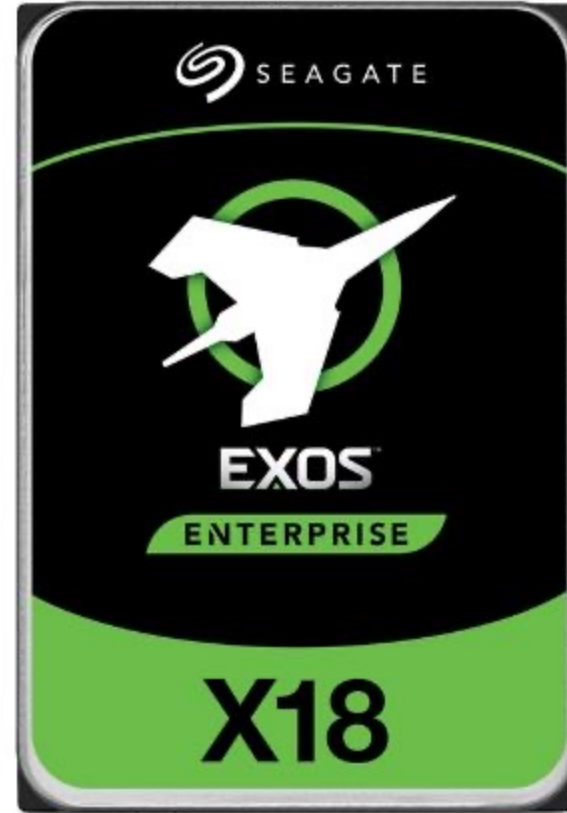

Solid State Disks (SSDs)

- 1995 – Replace rotating magnetic media with non-volatile memory (battery backed DRAM)
- 2009 – Use NAND Multi-Level Cell (2 or 3-bit/cell) flash memory
 - Sector (4 KB page) addressable, but stores 4-64 “pages” per memory block
 - Trapped electrons distinguish between 1 and 0
- No moving parts (no rotate/seek motors)
 - Eliminates seek and rotational delay (< 0.1-0.2ms access time)
 - Very low power and lightweight
 - Limited “write cycles”
- Rapid advances in capacity and cost ever since!

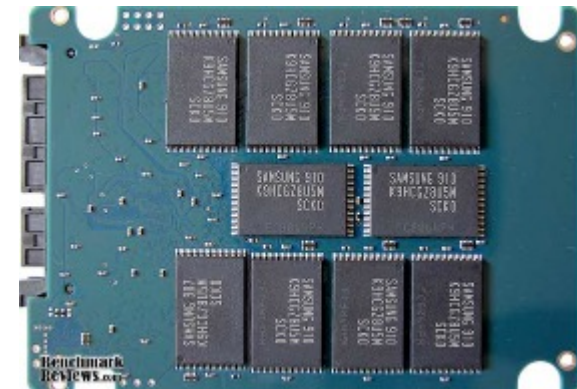

SSD Architecture – Reads

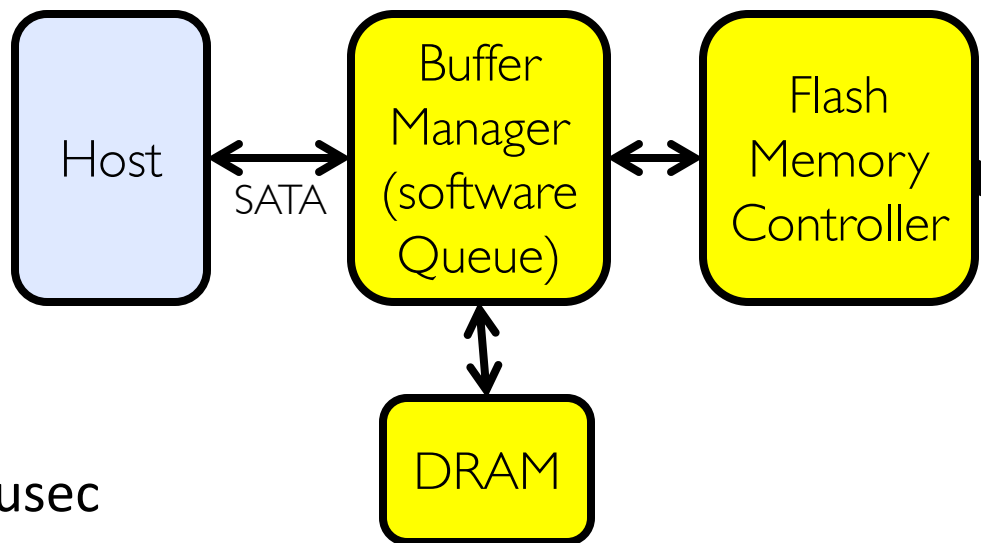

Read 4 KB Page: ~25 usec

- No seek or rotational latency
- Transfer time: transfer a 4KB page
 - » SATA: $300\text{-}600\text{MB/s} \Rightarrow \sim 4 \times 10^3 \text{ b} / (400 \times 10^6 \text{ bps}) \Rightarrow 10 \text{ us}$
- Latency = Queuing Time + Controller time + Xfer Time
- Highest Bandwidth: Sequential OR Random reads

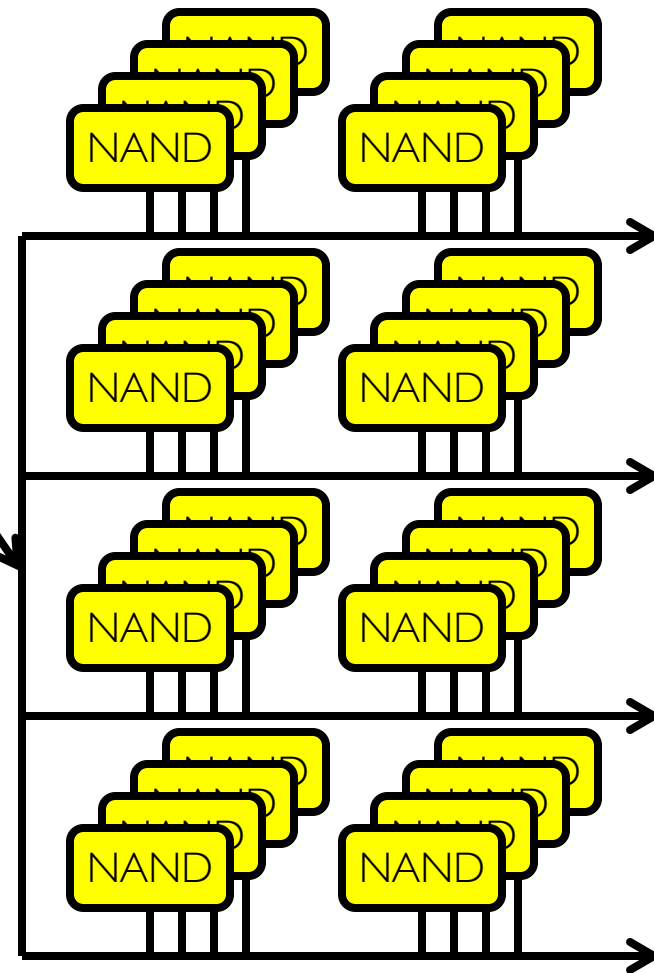

SSD Architecture – Writes

- Writing data is complex! (~200μs – 1.7ms)
 - Can only write empty pages in a block
 - Erasing a block takes ~1.5ms
 - Controller maintains pool of empty blocks by coalescing used pages (read, erase, write), also reserves some % of capacity
- Rule of thumb: writes 10x reads, erasure 10x writes

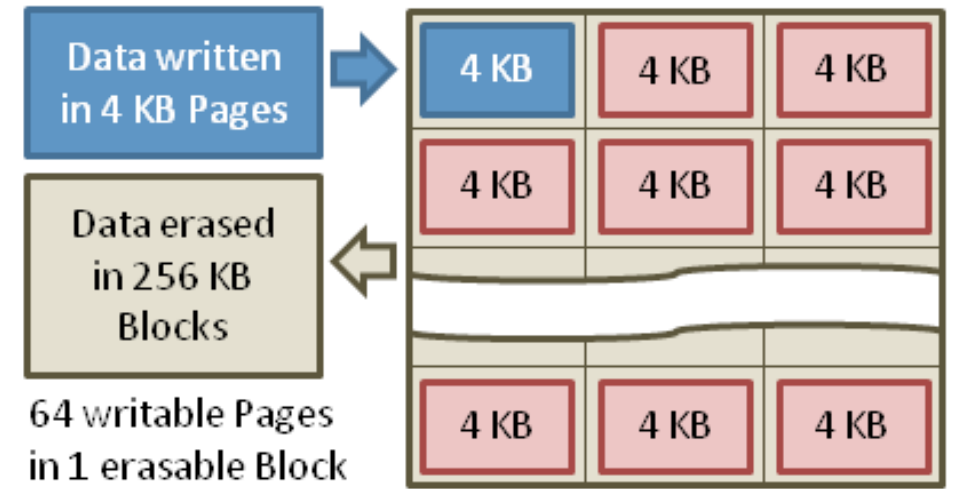

Typical NAND Flash Pages and Blocks

https://en.wikipedia.org/wiki/Solid-state_drive

SSD Architecture – Writes

- SSDs provide same interface as HDDs to OS – read and write chunk (4KB) at a time
- But can only overwrite data 256KB at a time!
- Why not just erase and rewrite new version of entire 256KB block?
 - Erasure is very slow (milliseconds)
 - Each block has a finite lifetime, can only be erased and rewritten about 10K times
 - Heavily used blocks likely to wear out quickly

Solution – Two Systems Principles

1. Layer of Indirection

- Maintain a *Flash Translation Layer (FTL)* in SSD
- Map virtual block numbers (which OS uses) to physical page numbers (which flash memory controller uses)
- **Can now freely relocate data w/o OS knowing**

2. Copy on Write

- Don't overwrite a page when OS updates its data (this is slow as we need to erase page first!)
- Instead, write new version in a free page
- Update FTL mapping to point to new location

Flash Translation Layer

- No need to erase and rewrite entire 256KB block when making small modifications
- SSD controller can assign mappings to spread workload across pages
 - *Wear Levelling*
- What to do with old versions of pages?
 - *Garbage Collection* in background
 - Erase blocks with old pages, add to free list

Some “Current” (large) 3.5in SSDs

- Seagate Exos SSD: 15.36TB (2017)
 - Dual 12Gb/s interface
 - Sequential reads: 860MB/s
 - Sequential writes: 920MB/s
 - Random Reads (IOPS): 102K
 - Random Writes (IOPS): 15K
 - Price (Amazon): \$5495 (\$0.36/GB)
- Nimbus SSD: 100TB (2019)
 - Dual port: 12Gb/s interface
 - Sequential reads/writes: 500MB/s
 - Random Read Ops (IOPS): 100K
 - *Unlimited writes for 5 years!*
 - Price: ~ \$40K? (\$0.4/GB)
 - » However, 50TB drive costs \$12500 (\$0.25/GB)

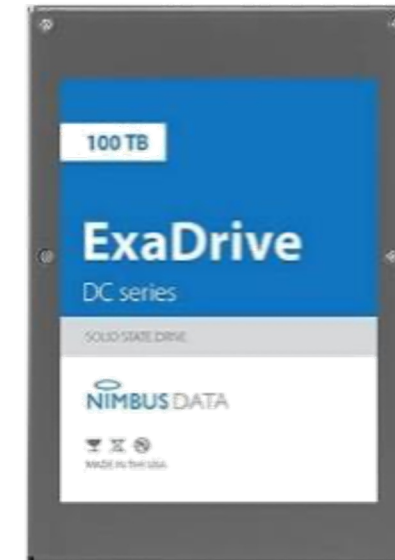

HDD vs. SSD Comparison

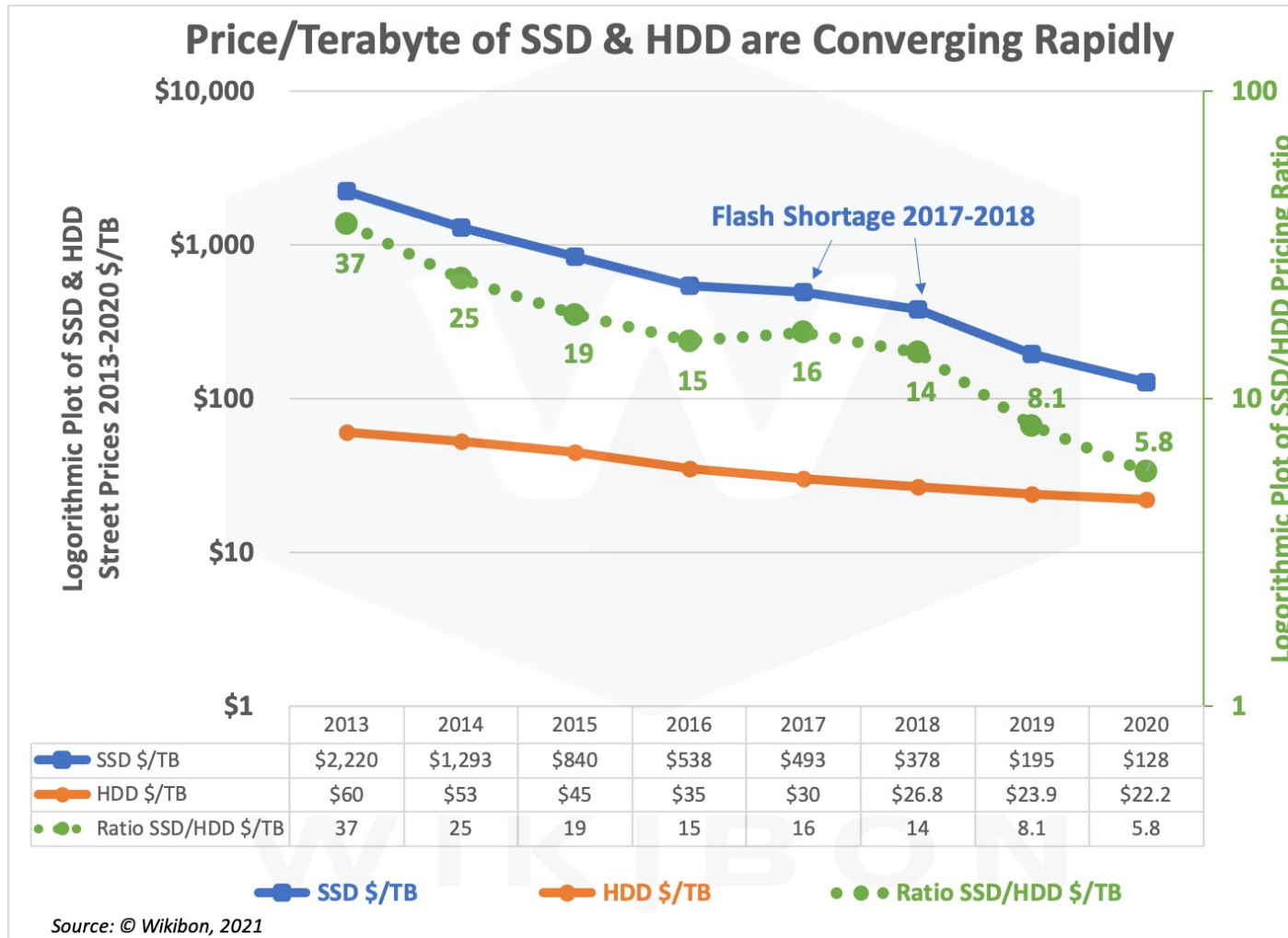

SSD vs HDD

Usually 10 000 or 15 000 rpm SAS drives

0.1 ms	Access times SSDs exhibit virtually no access time	5.5 ~ 8.0 ms
SSDs deliver at least 6000 i/o/s	Random I/O Performance SSDs are at least 15 times faster than HDDs	HDDs reach up to 400 i/o/s
SSDs have a failure rate of less than 0.5 %	Reliability This makes SSDs 4 - 10 times more reliable	HDD's failure rate fluctuates between 2 ~ 5 %
SSDs consume between 2 & 5 watts	Energy savings This means that on a large server like ours approximately 100 watts are saved	HDDs consume between 6 & 15 watts
SSDs have an average I/O wait of 1 %	CPU Power You will have an extra 6% of CPU power for other operations	HDDs' average I/O wait is about 7 %
the average service time for an I/O request while running a backup remains below 20 ms	Input/Output request times SSDs allow for much faster data access	the I/O request time with HDDs during backup rises up to 400 ~ 500 ms
SSD backups take about 6 hours	Backup Rates SSDs allows for 3 - 5 times faster backups for your data	HDD backups take up to 20 ~ 24 hours

SSD prices drop faster than HDD

SSD Summary

- Pros (vs. hard disk drives):
 - Low latency, high throughput (eliminate seek/rotational delay)
 - No moving parts:
 - » Very light weight, low power, silent, very shock insensitive
 - Read at memory speeds (limited by controller and I/O bus)
- Cons
 - Small storage (0.1-0.5x disk), expensive (3-20x disk)
 - » Hybrid alternative: combine small SSD with large HDD

SSD Summary

- Pros (vs. hard disk drives):

- Low latency, high throughput (eliminate seek/rotational delay)
- No moving parts:
 - » Very light weight, low power, silent, very shock insensitive
- Read at memory speeds (limited by controller and I/O bus)

No longer true!

- Cons

- ~~Small storage (0.1-0.5x disk), expensive (3-20x disk)~~
 - » Hybrid alternative: combine small SSD with large HDD
- Asymmetric block write performance: read pg/erase/write pg
 - » Controller garbage collection (GC) algorithms have major effect on performance
- Limited drive lifetime
 - » 1-10K writes/page for multi-level cell (MLC) NAND
 - » Avg failure rate is 6 years, life expectancy is 9–11 years

- These are changing rapidly!

Conclusion (1/2)

- I/O Devices Types:
 - Many different speeds (0.1 bytes/sec to GBytes/sec)
 - Different Access Patterns:
 - » Block Devices, Character Devices, Network Devices
 - Different Access Timing:
 - » Blocking, Non-blocking, Asynchronous
- I/O Controllers: Hardware that controls actual device
 - Processor Accesses through I/O instructions, load/store to special physical memory
- Notification mechanisms
 - Interrupts
 - Polling: Report results through status register that processor looks at periodically
- Device drivers interface to I/O devices
 - Provide clean Read/Write interface to OS above
 - Manipulate devices through PIO, DMA & interrupt handling
 - Three types: block, character, and network

Conclusion (2/2)

- Disk Performance:
 - Queuing time + Controller + Seek + Rotational + Transfer
 - Rotational latency: on average $\frac{1}{2}$ rotation
 - Transfer time: spec of disk depends on rotation speed and bit storage density
- Devices have complex interaction and performance characteristics
 - Response time (Latency) = Queue + Overhead + Transfer
 - » Effective BW = $BW * T / (S+T)$
 - HDD: Queuing time + controller + seek + rotation + transfer
 - SSD: Queuing time + controller + transfer (erasure & wear)
- Systems (e.g., file system) designed to optimize performance and reliability
 - Relative to performance characteristics of underlying device